

5
axis

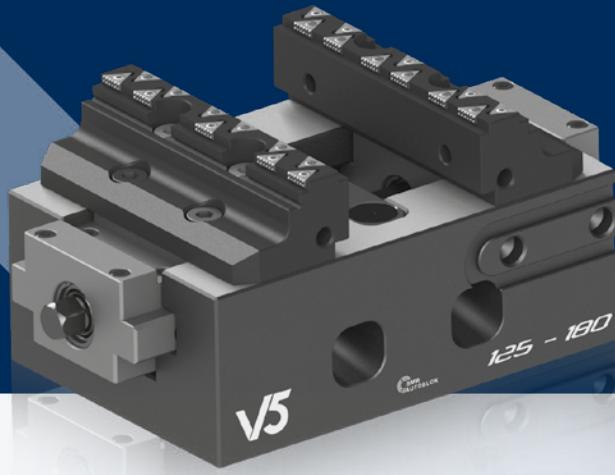

V5

5.2

**Self-centering vice
for 5-axis machines**



V5 88-130

Page 5.2.4



V5 125-180

Page 5.2.5



V5
Working example

Page 5.2.6

V5

Self-centering vice
for 5-axis machines



Self-centering vice for 5-axis machines

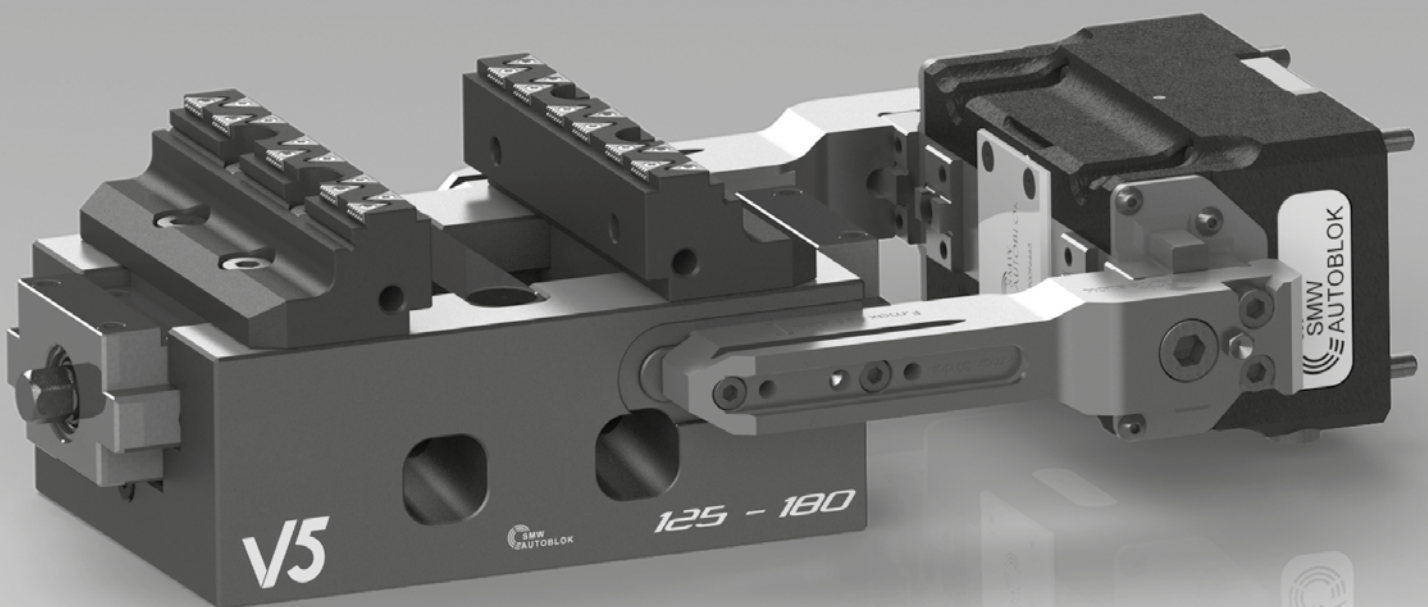

V5

5.2

Self-centering vice for 5-axis machines

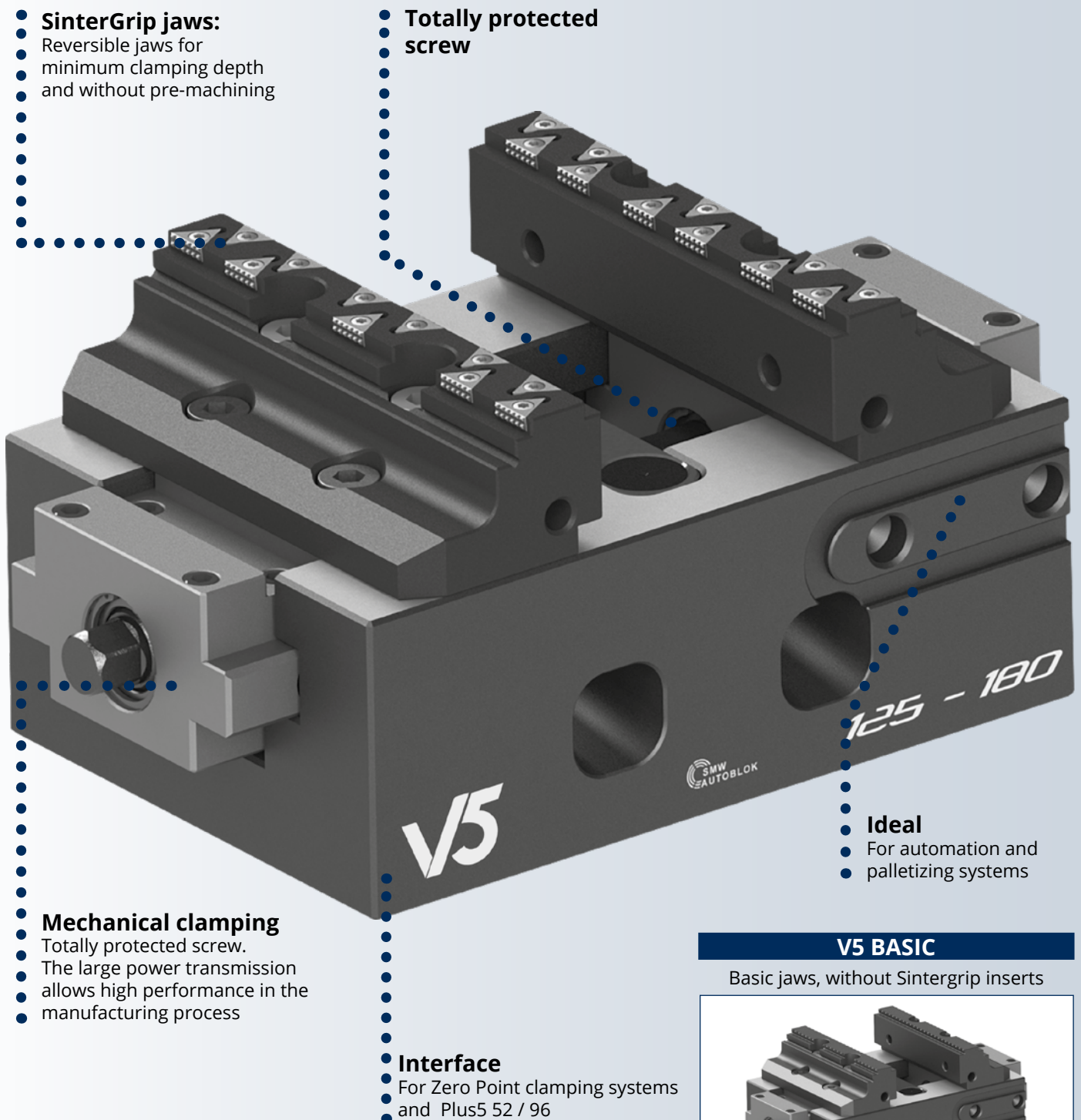

V5 BASIC

Basic jaws, without Sintergrip inserts



■ Patented protected screw

Applications / Customer Benefits

- Highly precise **only** self-centering clamping with maximum repeatability
- Totally protected
- Compact design for better accessibility and very large drainage slots
- Jaws with SinterGrip clamping inserts for minimum workpiece clamping depth without pre-machining
- Wide clamping range
- Ideal for OP 10 and OP 20

Technical features

- Self-centering clamping
- Clamping force up to 32 kN (50 Nm)
- Jaw width 87,5 mm
- Interface for Zero Point system APS / TDM and Plus5 52
- **The jaws for V5 88 are compatible with IMG 88.**

Standard equipment

Wrench, jaws, nr. 10 Sintergrip inserts.

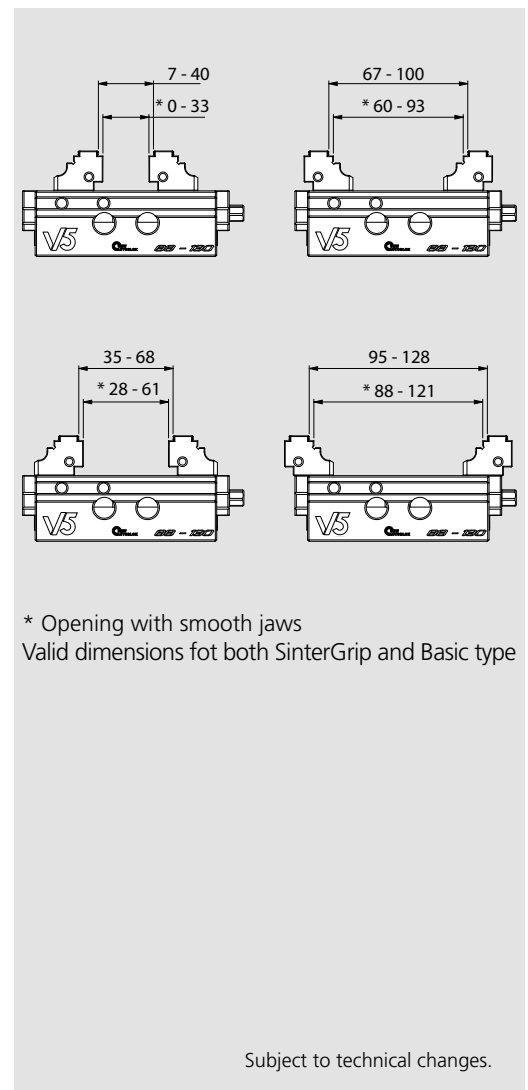
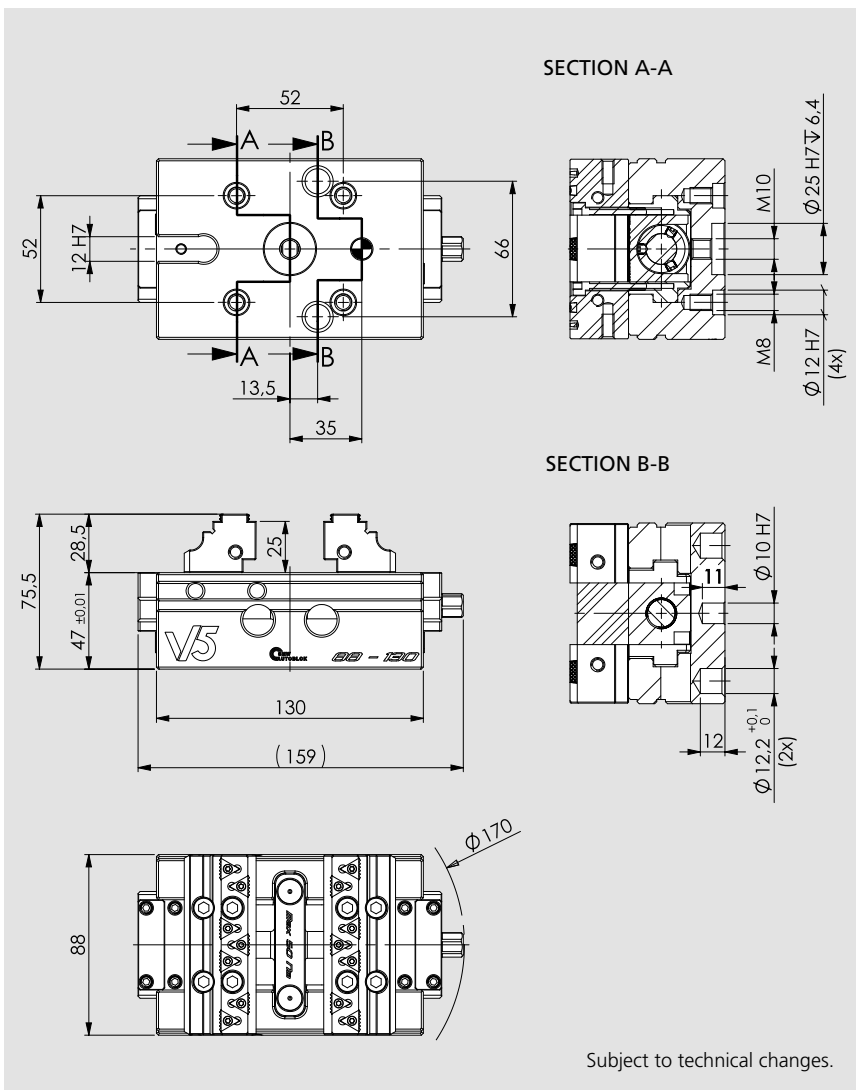

Type	Id. No.	Weight
V5 88 - 130 with SinterGrip jaws STD	77583303	4,5 Kg
V5 88 - 130 with SinterGrip jaws HRC	77583304	4,5 Kg
V5 88 - 130 with SinterGrip jaws ALU	77583305	4,5 Kg
V5 88 - 130 Basic	77583302	4,5 Kg
V5 88 - 130 body only	77583301	3,5 Kg

■ Patented protected screw



Applications / Customer Benefits

- Highly precise **only** self-centering clamping with maximum repeatability
- Totally protected
- Compact design for better accessibility and very large drainage slots
- Jaws with SinterGrip clamping inserts for minimum workpiece clamping depth without pre-machining
- Wide clamping range
- Ideal for OP 10 and OP 20

Technical features

- Self-centering clamping
- Clamping force up to 40 kN (80 Nm)
- Jaw width 125 mm
- Interface for Zero Point system APS / TDM and Plus 5 52 - 96
- **The jaws for V5 125 are compatible with IMG 125.**

Standard equipment

Wrench, jaws, nr. 10 Sintergrip inserts.

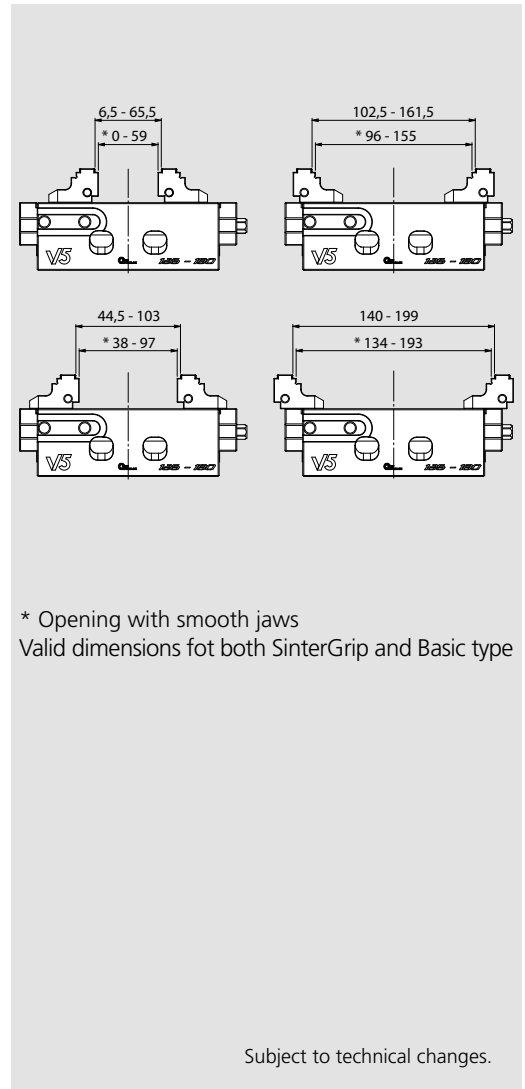
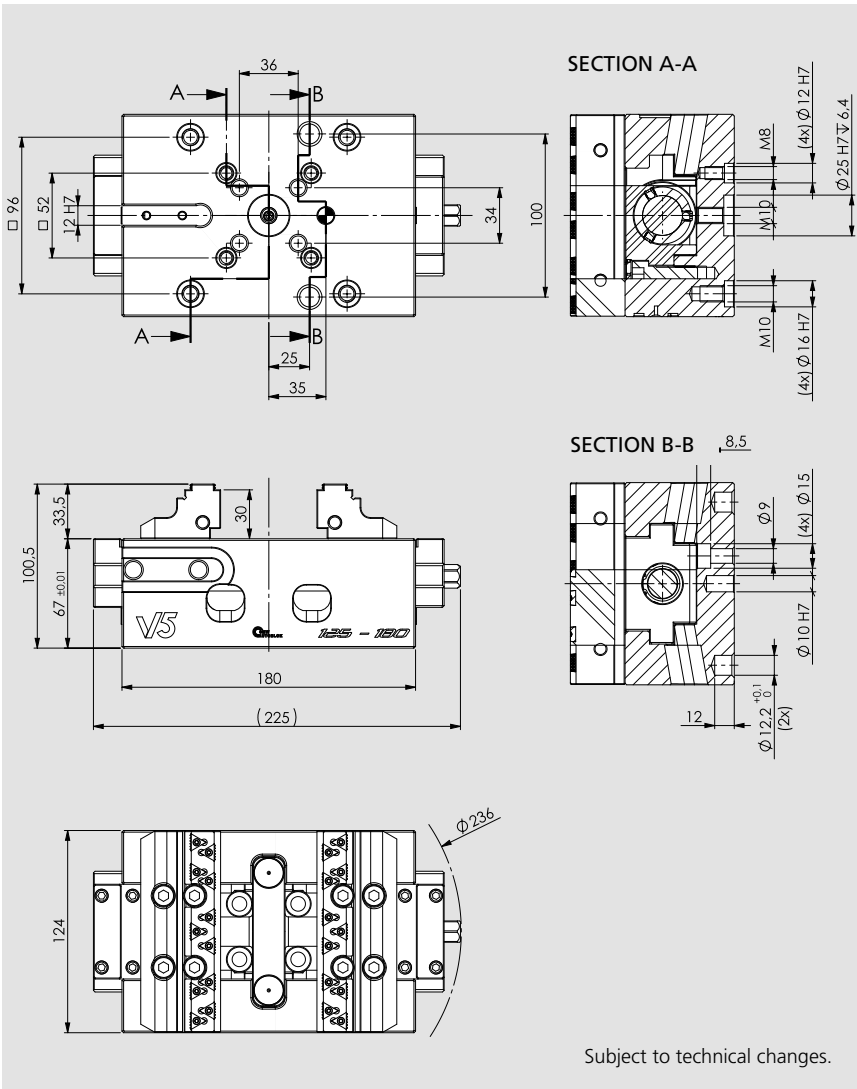

Type	Id. No.	Weight
V5 125 - 180 with SinterGrip jaws STD	77583333	12 Kg
V5 125 - 180 with SinterGrip jaws HRC	77583334	12 Kg
V5 125 - 180 with SinterGrip jaws ALU	77583335	12 Kg
V5 125 - 180 Basic	77583332	12 Kg
V5 125 - 180 body only	77583331	10 Kg

The self-centering **only** V5 vice is added to the IMG range with an excellent quality-price ratio, ideal for multi-vice integrated automation systems.

Working example

