

TOUCHDEX

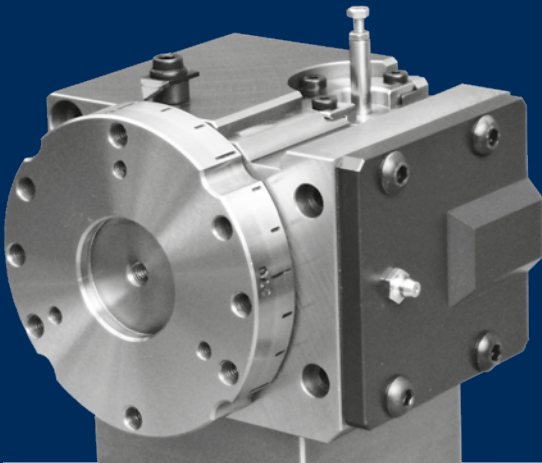

Automatic mechanical indexing tables

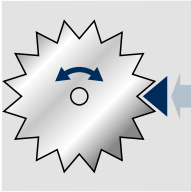

Description and operating instructions

Page 15.3

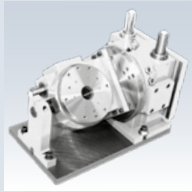

TILTING

Page 15.15

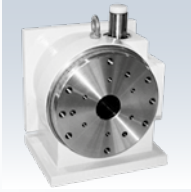

TOUCHDEX indexing tables

Page 15.8

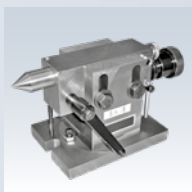

Accessories

Page 15.16

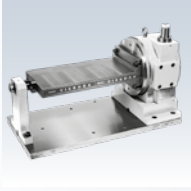

COMBIDEX

Page 15.14

HIGH RIGIDITY AND PRECISION OF THE SYSTEM

TOUCHDEX

CNC System

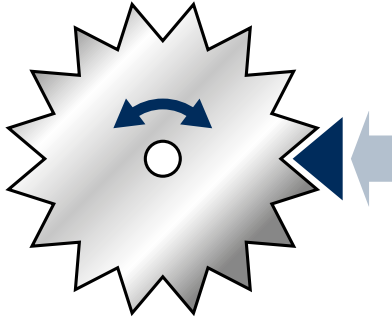

Exclusive Mechanical clamping System "LOCKING PIN"

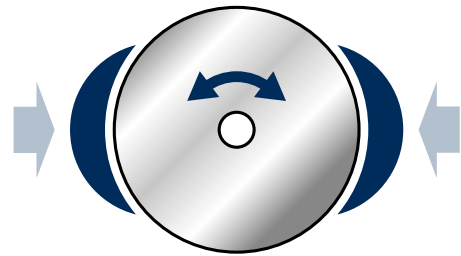

Traditional braking jaws system

The exclusive TOUCHDEX system provides a clamping force 2 to 3 times that an ordinary index table thus allowing heavy machining.

Example	Face Milling	Drilling	Drilling
Machining S45C Material			
FD-200	Δ 80 Face mill 3 mm (depth of cut) 130 mm/min (Feedrate)	Δ 35 Drill 20 mm/min (Feedrate)	Δ 20 Drill 30 mm/min (Feedrate) H = 80 mm
FD-300	Δ 80 Face mill 3 mm (depth of cut) 130 mm/min (Feedrate)	Δ 40 Drill 20 mm/min (Feedrate)	Δ 25 Drill 30 mm/min (Feedrate) H = 90 mm

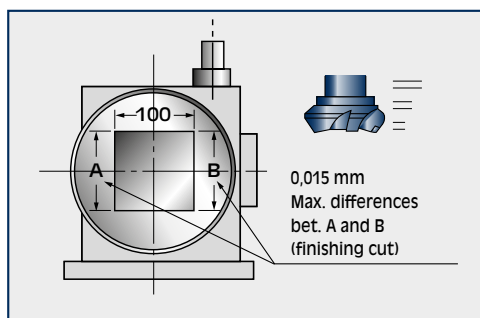

HIGH PRECISION

- Indexing accuracy of less than 30"
- Repeat accuracy ± 3"

The unique clamping system ensures high accuracy despite locking pin wear, and with 0 backlash for the life of the unit (see example)

VERSATILITY OF THE SYSTEM

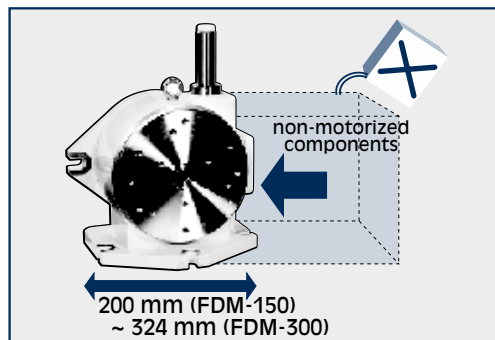

- **Minimum space required**

Since it has no motorized part, it can be installed in a minimum amount of space



- **Versatility**

Since it has no electric or pneumatic connections, it can be installed on MULTI-PALLET machining centers either vertical or horizontal with the possibility to create flexible production systems

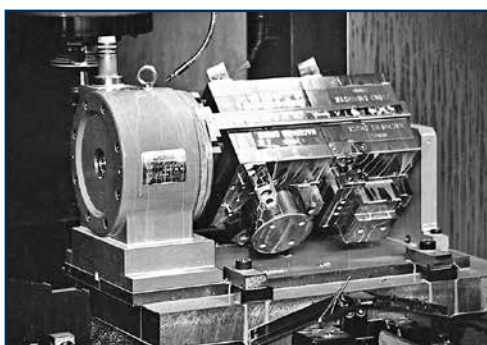
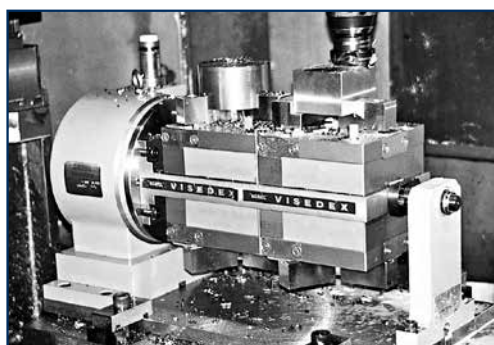
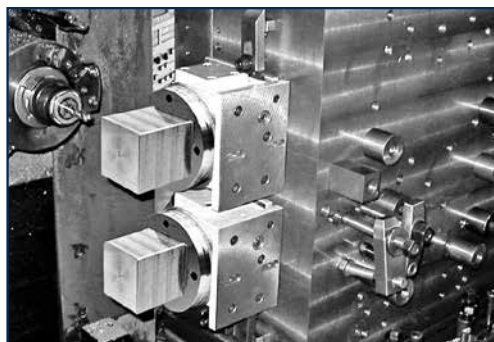

- **Easily mounted**

As a power control cable is not required the displacement from a machining center to another one is very easy

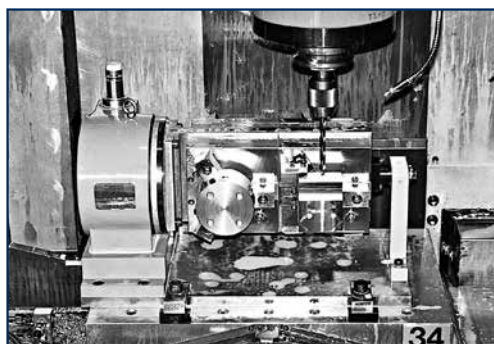

VARIETY OF TOUCHDEX MODELS AVAILABLE

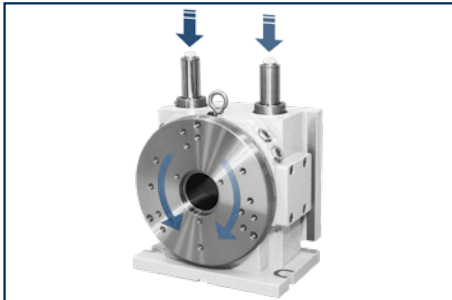

FDR

Indexing and rotation in TWO directions

- Left pushbar for counterclockwise
- Right pushbar for clockwise



FDM

With the adaption for the installation either in horizontal or in vertical

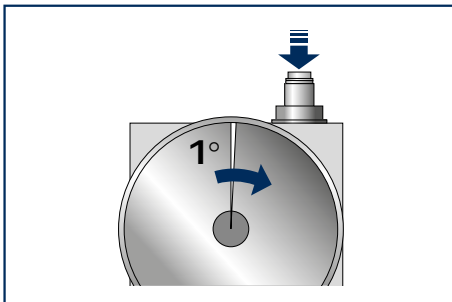

FD - ... - 360

1 deg. Indexing ideal for workpieces of complex shape

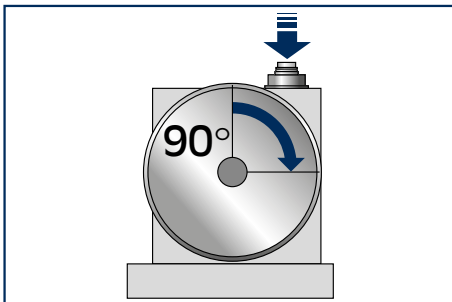

FD - ... - 04

90 deg. Indexing rotation per stroke. Pressing the pushbar down one rotate the table by 90 deg. Ideal for square workpieces

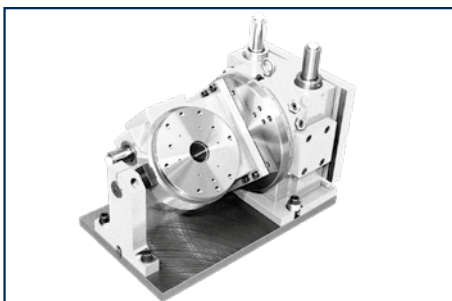

TILTING 230-150

Five-face machining. Integrates FDR-230 and FDM-150 for five-face machining on vertical machining centers

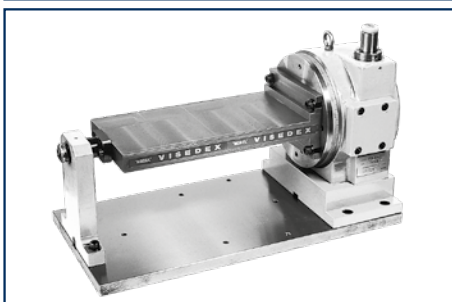

COMBIDEX

Integrates subplate and plate for workholding applications

WORKING

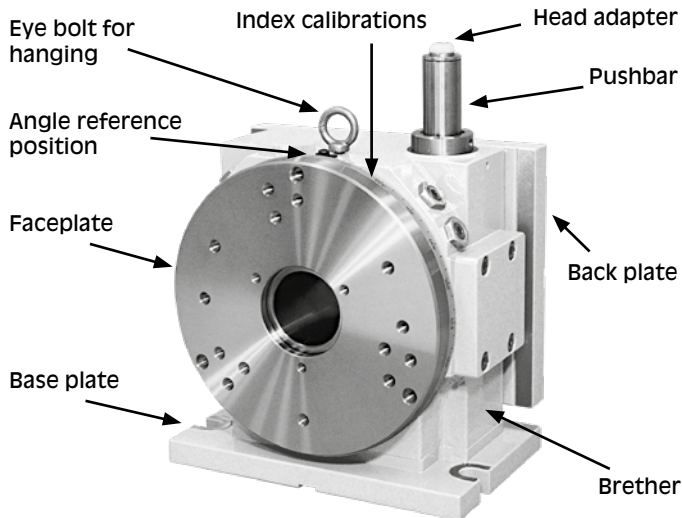

INTERNAL MECHANISM

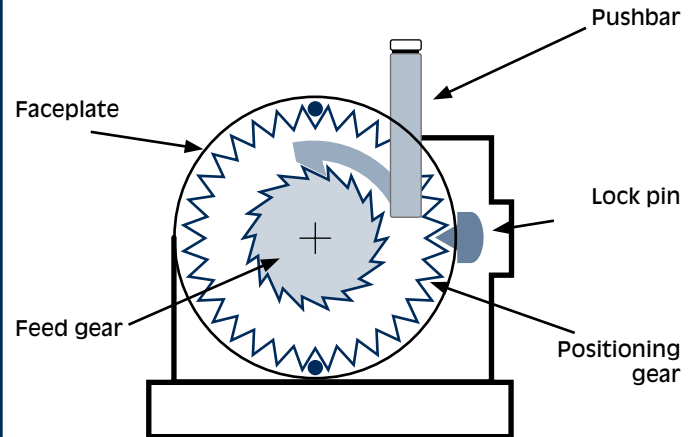

- 1** When the pushbar is pressed down a little, the lock pin retracts due to a grooved cam mechanism.

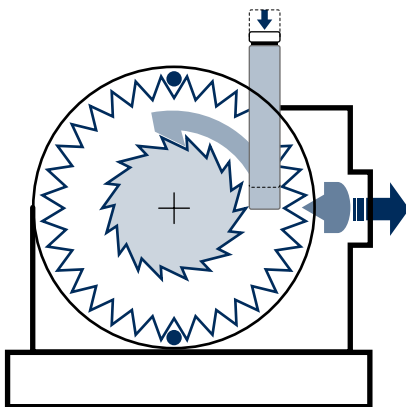

- 2** When pressed down further, the faceplate begins to rotate.

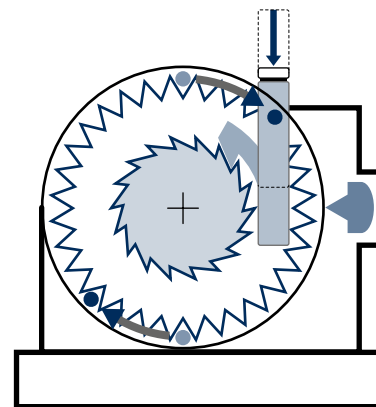

- 3** The pushbar returns, but until a certain position is reached the faceplate and the lock pin continue to be as they were.

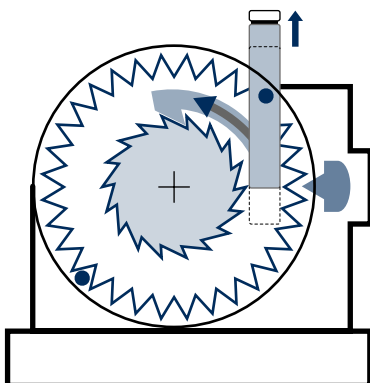

- 4** When the pushbar reaches the top most position, the lock pin engages with the positioning gear and fixes the table.

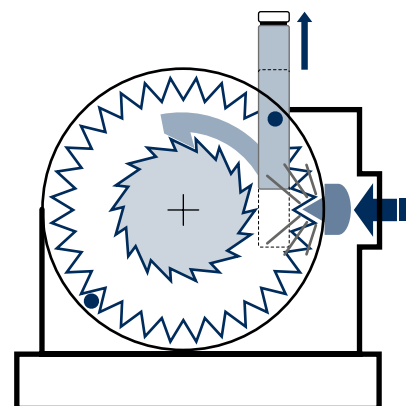

PROGRAMMING

*** POSITION A** Using handle mode.

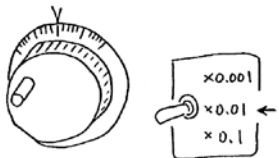

Do not rotate the tool!

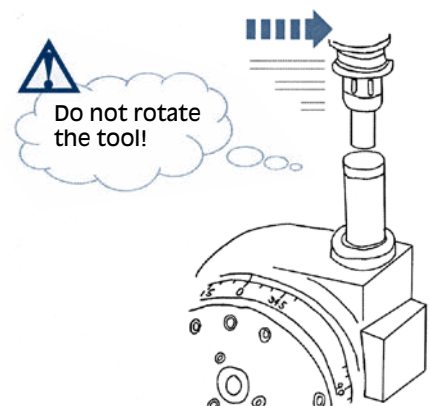

Move the tool over the pushbar, using manual mode.

Read and memory Z axis number.

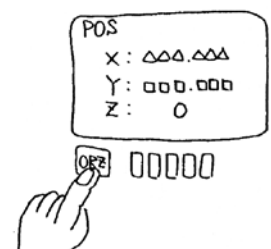

*** POSITION B** Using handle mode.

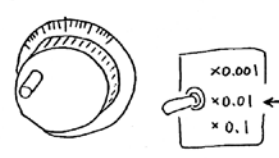

Adjust the indexing as accurately as your eyes can master.

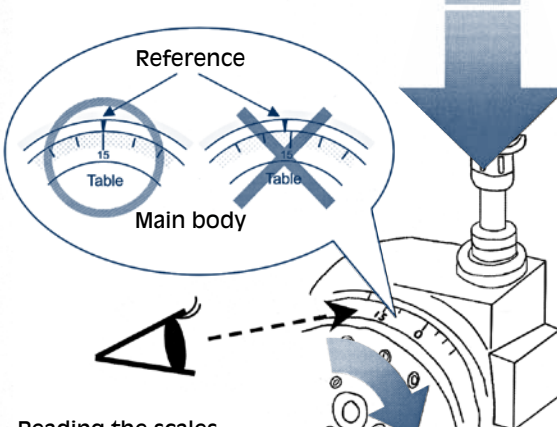

Reading the scales on the side of the table, move the Z axis with manual handle mode until the indexing is completed.

Read and memory Z axis number.

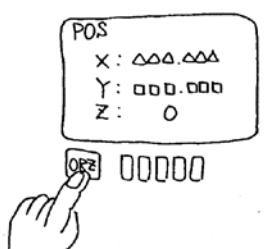

PROGRAM

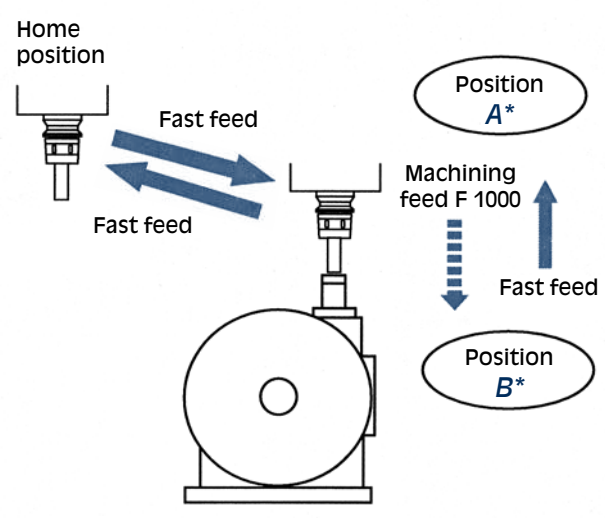

INFORMATION

Regarding the push-in tool

Providing the drill is \varnothing 10 mm or wider and no bending is caused during the pushing down, the tool you are using is appropriate.

If a tool with a sharp tip is used, it will badly wear down the resin and the resin will have to be replaced.

The main shaft cover can also be used to push down.

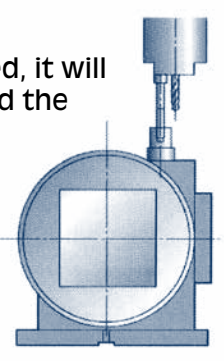

Code	Type	Indexing angles		Pushbar Stroke mm
		Min°	Max °	
51 99 13 20	FDK-450	5°	45°	93

FDK-450



New

LARGEST TOUCHDEX

Table Dia 450mm

Large Center Hole Secured



Standard equipment with a Brake Ring Function

Brake Ring Function. This function suppresses a decrease in clamping force during indexing by continuously applying a constant friction force to the table. This function can respond to more unbalanced workpieces / jigs

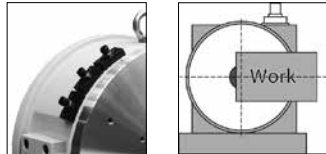

A manual indexing unit (MH-6) is supplied as standard accessory

With a lock cancelation function

Manual Unit MH-6
(stroke: 15mm)

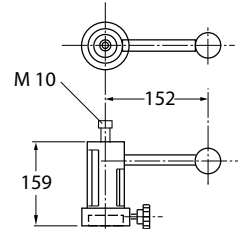

Type	FDK-450	
Table Diameter	mm	450
Center Height	mm	250
Spindle Bore Diameter	mm	120
Table indexing angles at full pushbar stroke	deg.	45
Min. indexing angles	deg.	5
Approx. Full pushbar stroke	mm	93
Approx. pushbar load	N [kgf]	1960 [200]
Loadings	kg	450
Allowable Unbalanced weight (differences in load at table periphery)	kg	40
Allowable load (Table clamped)	N-m [kgf-m]	4560 [465]
Accuracy	sec	30
Repeatability	sec	± 3
Weight	kg	214

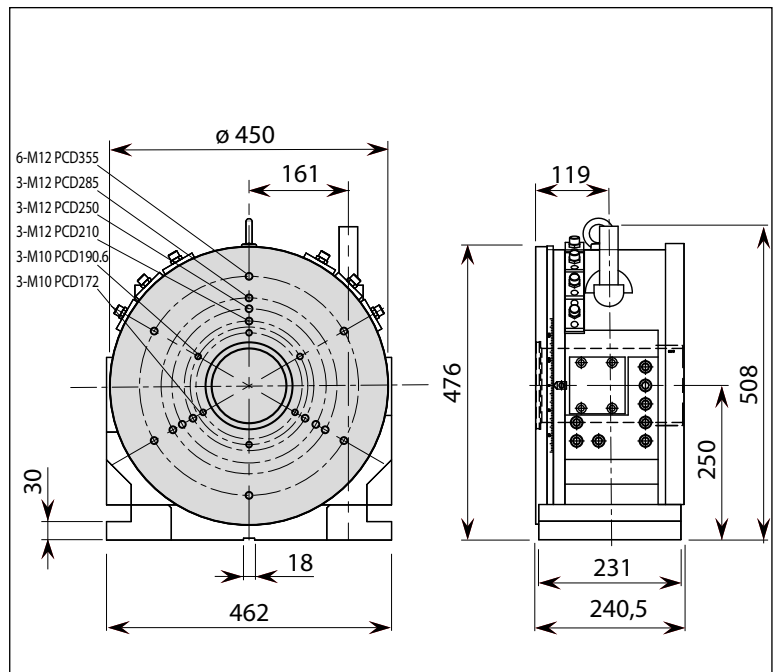

Code	Type	Indexing angles		Pushbar Stroke mm
		Min°	Max °	
51 99 13 59	FD-107	15°	45°	24

FD-107

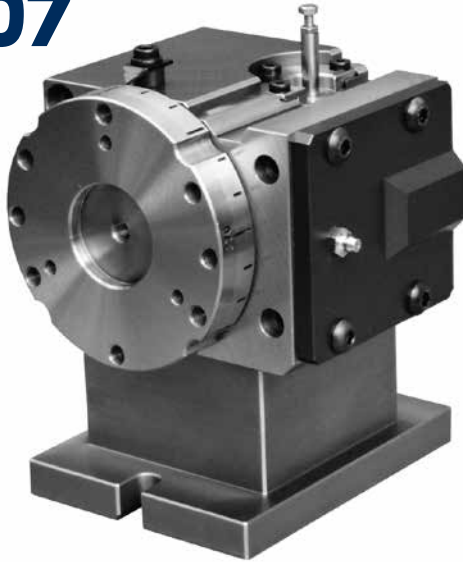

New

SMALLEST TOUCHDEX Table Dia 107mm

- Light-weight Compact
- Weight: 13kg
- Table indexing angles at full pushbar stroke: 45 deg.
- Min. indexing angles: 15 deg.

The detachable base plate diversifies mounting ways

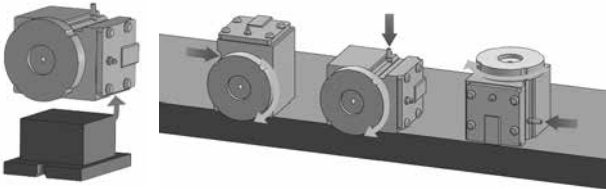

Example of installation

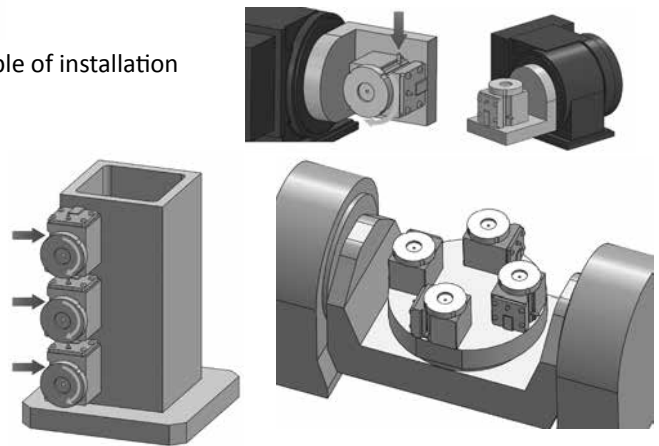

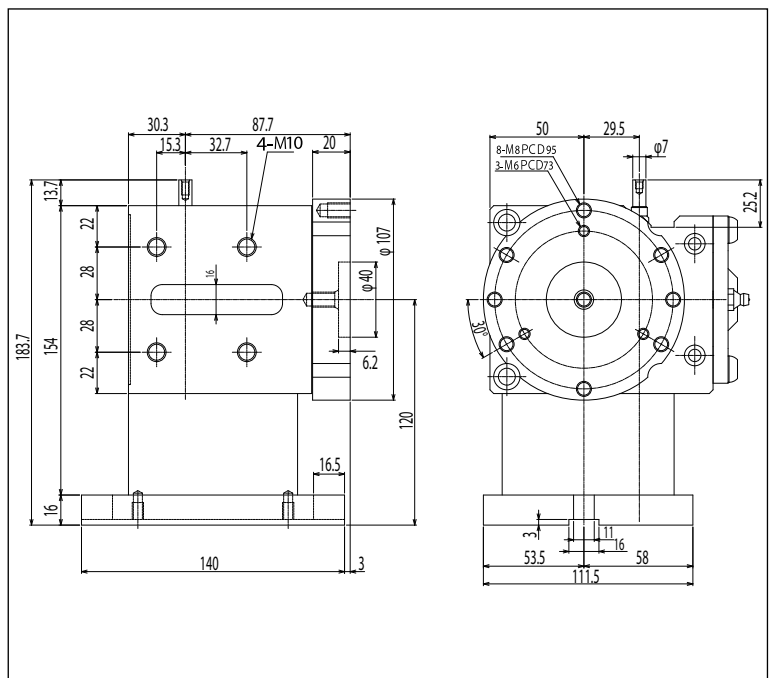

Type		FD-107
Table Diameter	mm	107
Center Heigh	mm	120
Spindle Bore Diameter	mm	-
Table indexing angles at full pushbar stroke	deg.	45
Min. indexing angles	deg.	15
Approx. Full pushbar stroke	mm	24
Approx. pushbar load	N [kgf]	295 [30]
Loadings	kg	20
Allowable Unbalanced weight (differences in load at table periphery)	kg	4
Allowable load (Table clamped)	N-m [kgF-m]	196 [20]
Accuracy	sec	60
Repeatability	sec	± 3
Weight	kg	13

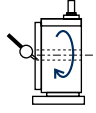
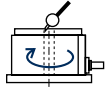
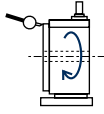
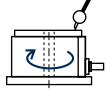
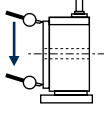
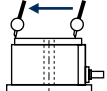

TOLERANCES

Inspecting item	Tollerances	Measurement Method (FD)	Measurement Method (FDM)
Table Center Hole Run-out	0.01 mm		
Table Surface Run-out (15 mm inside table periphery)	0.01 mm		
Table Surface Squareness (15 mm inside table periphery)	0.03 mm		

SPECIFICATIONS

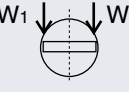
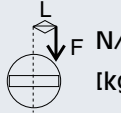
Type		FDM-150	FDMK-150-04	FD-200-04
Table diameter	mm	170	170	210
Spindle bore diameter	mm	37	37	16.5
Center height	mm	120	120	135
Table indexing angles at full pushbar stroke	gradi	45	90	90
Min. indexing angles	gradi	5	5	5
Full pushbar stroke	mm	38	53	78
Approx. pushbar load	N [kgf]	295 [30]	392 [40]	784 [80]
Loadings	vertical use  kg	200	200	250
	horizontal use  kg	300	300	---
Allowable unbalanced weight <small>differences in load at table periphery</small>	$W_1 - W_2$  kg	4	20	4
Allowable load <small>(Table clamped)</small>	$F \times L$  N/m [kgf/m]	588 [60]	588 [60]	1030 [105]
Accuracy	sec	30	30	30
Ripeatability	sec	±3	±3	±3
Weight	kg	30	37	38

Code	Type	Indexing Angles		Pushbar Stroke mm	A mm
		Min °	Max °		
51 99 13 01	FDM-150	5°	45°	38	127

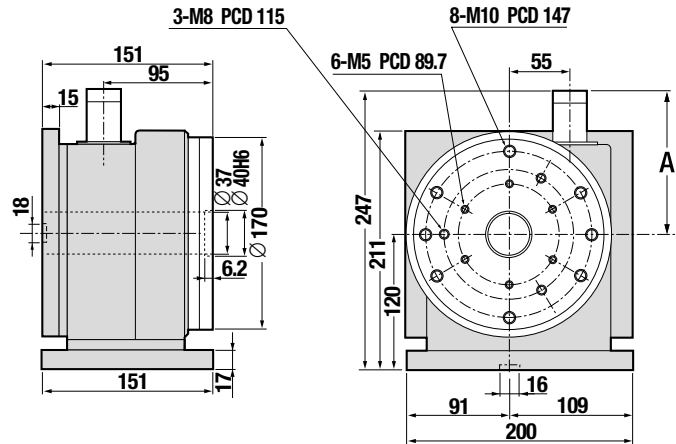
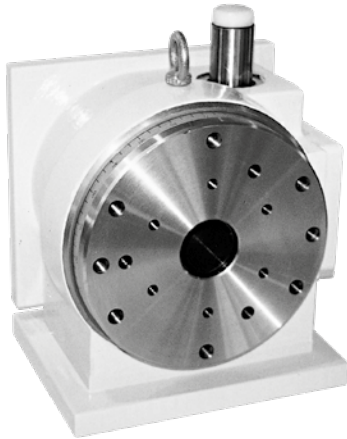



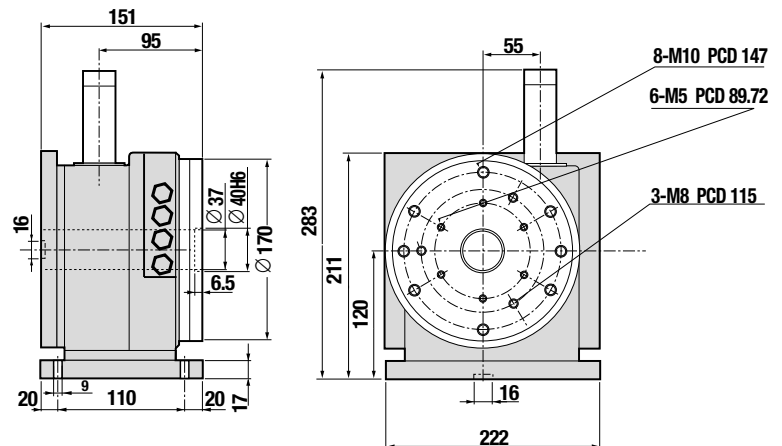
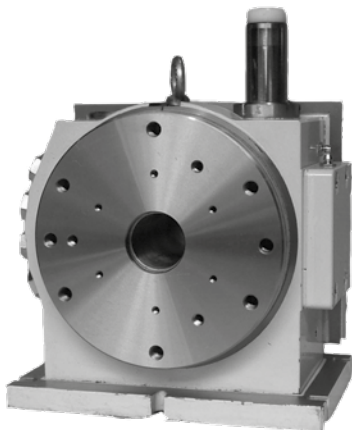

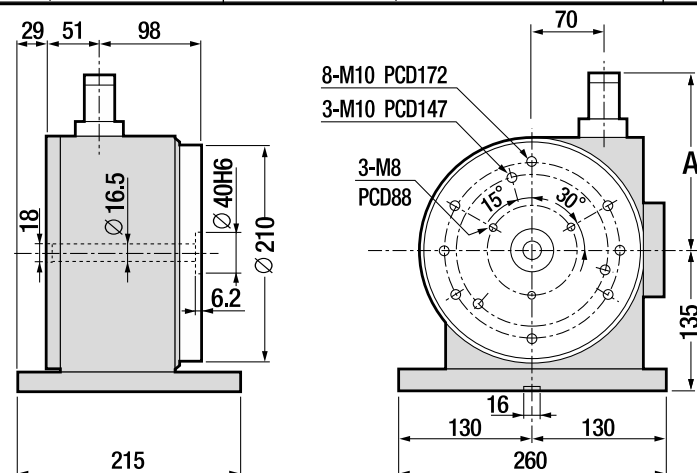

Code	Type	Indexing Angles		Pushbar Stroke mm	A mm
		Min °	Max °		
51 99 13 16	FDMK-150-04	5°	90°	53	163



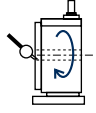

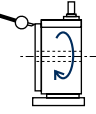
Code	Type	Indexing Angles		Pushbar Stroke mm	A mm
		Min °	Max °		
51 99 13 02	FD-200-04	5°	90°	78	208

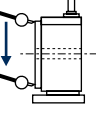

TOLERANCES

Inspecting item	Tollerances	Measurement Method (FD)	Measurement Method (FDM)
Table Center Hole Run-out	0.01 mm		
Table Surface Run-out (15 mm inside table periphery)	0.01 mm		
Table Surface Squareness (15 mm inside table periphery)	0.03 mm		

SPECIFICATIONS

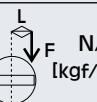
Type		FDM-230	FDM 230-360	FDR-230	FDR 230-360	FD-300	FD 300-360	FDMK 340	FDMK 340-360
Table Diameter	mm	230	230	230	230	310	310	340	340
Spindle Bore Diameter	mm	58	58	58	58	52	52	100	100
Center Height	mm	145	145	145	145	185	185	200	200
Table Indexing Angles at Full Pushbar Stroke	deg.	45	45	45	45	45	45	45	45
Min. Indexing Angles	deg.	5	1	5	1	5	1	5	1
Full Pushbar Stroke	mm	56	56	56	56	75	75	83	83
Approx. Pushbar Load	N [kgf]	784 [80]	784 [80]	1470 [150]	1470 [150]	1078 [110]	1078 [110]	1764 [180]	1764 [180]
Loadings	Vertical use  kg	250	250	250	250	350	350	350	350
	Horizontal use  kg	350	350	350	350	500	500	500	500
Allowable Unbalanced weight (differences in load at table periphery)	W ₁ - W ₂  kg	4	4	20	20	4	4	20	20
Allowable load (Table clamped)	F x L  N/m [kgf/m]	1127 [115]	1127 [115]	1127 [115]	1127 [115]	2280 [232.5]	2280 [232.5]	2280 [233]	2280 [233]
Accuracy	sec	30	30	30	30	30	30	30	30
Repeatability	sec	±3	±3	±3	±3	±3	±3	±3	±3
Weight	kg	42	42	48	48	80	80	98	98

Code	Model	Indexing Angles		Pushbar Stroke mm	A mm
		Min	Max		
51 99 13 04	FDM-230	5°	45°	56	198
51 99 13 05	FDM-230-360	1°	45°	56	198

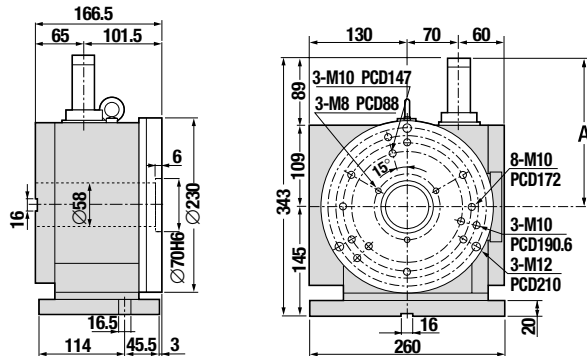
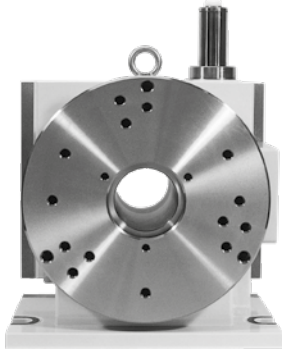

Code	Model	Indexing Angles		Pushbar Stroke mm	A mm
		Min	Max		
51 99 13 06	FDR-230	5°	45°	56	198
51 99 13 60	FDR-230-360	1°	45°	56	198

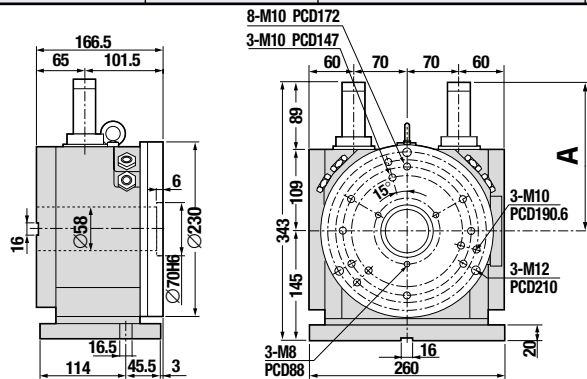
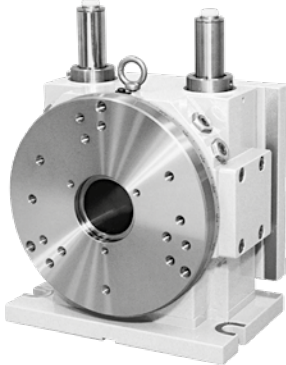

Code	Model	Indexing Angles		Pushbar Stroke mm	A mm
		Min	Max		
51 99 13 07	FD-300	5°	45°	75	233
51 99 13 08	FD-300-360	1°	45°	75	233

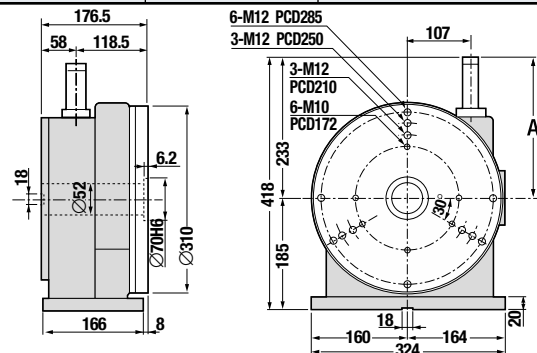
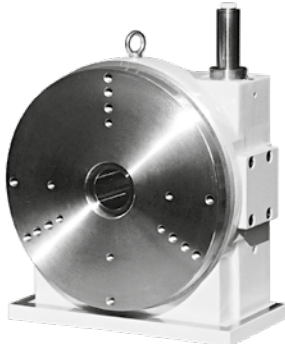

Code	Model	Indexing Angles		Pushbar Stroke mm	A mm
		Min	Max		
51 99 13 18	FDMK-340	5°	45°	83	240,5
51 99 13 19	FDMK-340-360	1°	45°	83	240,5

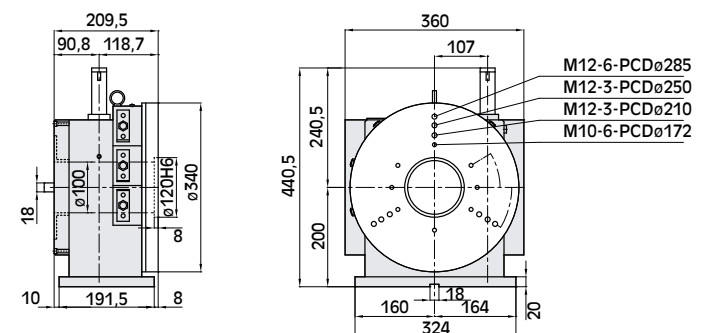
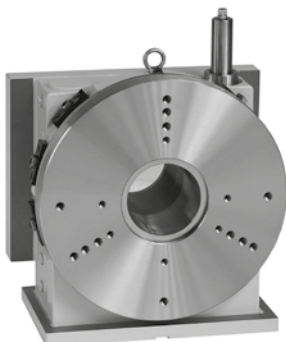

Code	Model	Indexing Angles		Pushbar Stroke mm	A mm
		Min	Max		
51 99 13 11	FDV-201-04	5°	90°	78	208

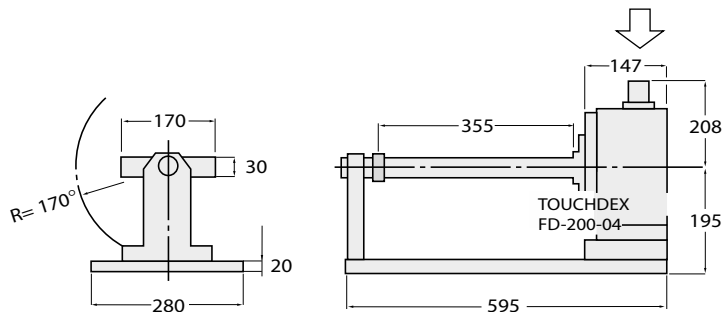
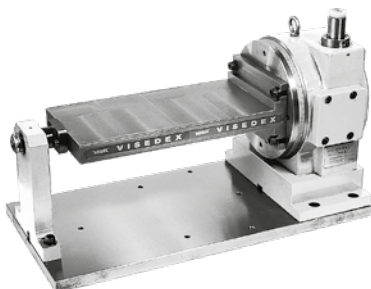

Code	Model	Indexing Angles		Pushbar Stroke mm	A mm
		Min	Max		
51 99 13 12	FDV-301	5°	45°	75	233

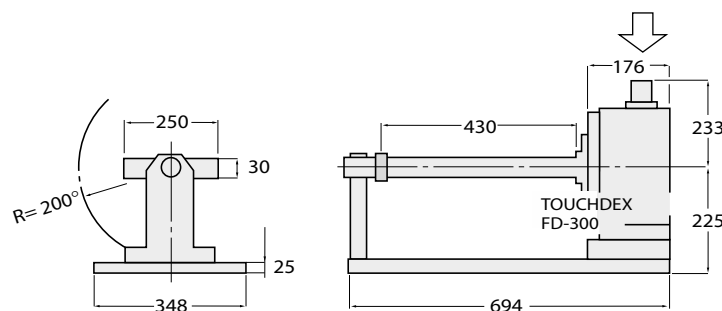
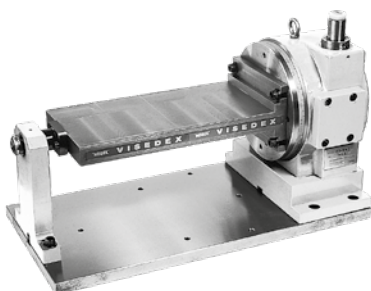

Examples

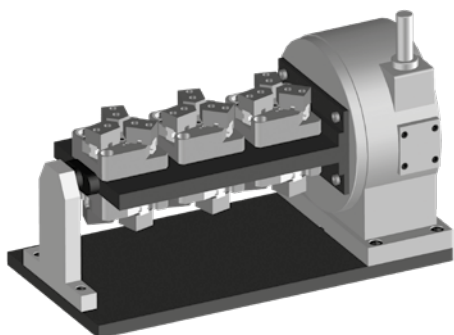

With SC square chuck

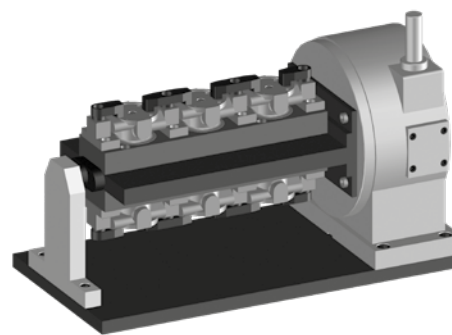

With clamping devices

With TC-t clamping system

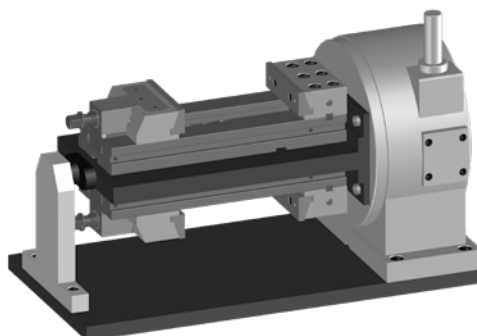

Code	type
51 99 13 13	TL 230-150

Code	type
51 99 13 14	TL 340-230

Integrates FDR-230 and FDM-150 + FDR-340 and FDM-230 for five-face machining on vertical machining centers.

- Table inclination and rotation adjusted automatically with the pushbar of TOUCHDEX.
- Minimum indexing angle in both inclination and rotation of 5°.
- Extremely compact footprint - 450 x 260 mm.

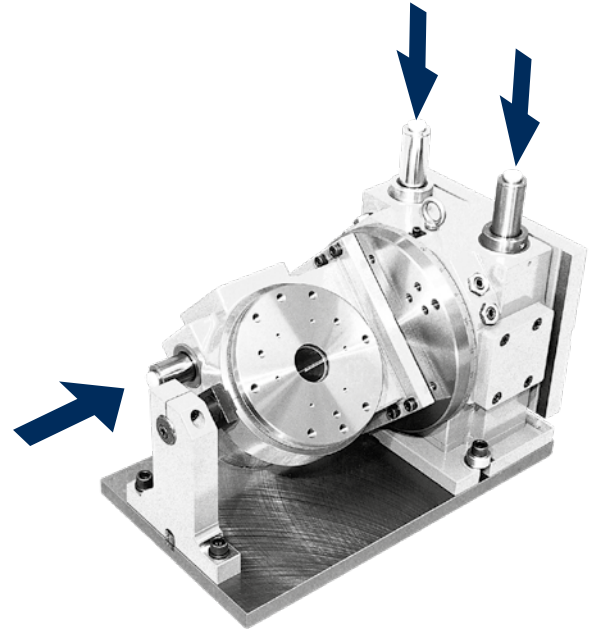

Specifications		TL 230-150	TL 340-230
Table Diameter	mm	170	230
Spindle Bore Diameter	mm	37	58
Center Height (90° Tilted)	mm	145	200
Table surface height (0 deg. tilted)	mm	200	265
Full Pushbar Stroke (Tilting)	mm	56	83
Full Pushbar Stroke (Rotation)	mm	38	56
Approx. Pushbar Load (Tilting)	N [kgf]	1470 [150]	1764 [180]
Approx. Pushbar Load (Rotation)	N [kgf]	295 [30]	1470 [150]
Loadings (0° to 90°)	kg	70	100
Allowable load (Table clamped)	 FxL N-m [kgf·m]	1127 [115]	1960 [200]
	 FxL N-m [kgf·m]	625 [63.8]	1.127 [115]
Accuracy (Tilting)	sec	30	30
Accuracy (Rotation)	sec	30	30
Repeatability (Tilting)	sec	±3	±3
Repeatability (Rotation)	sec	±3	±3
Weight	kg	98	215

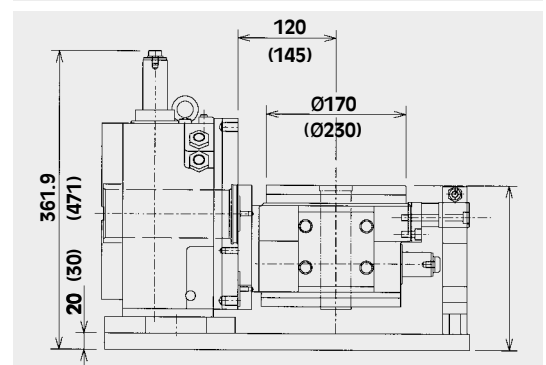
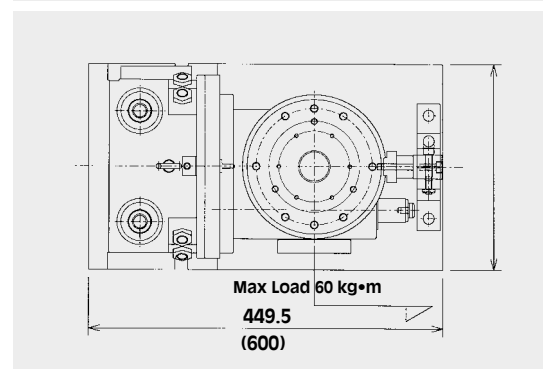
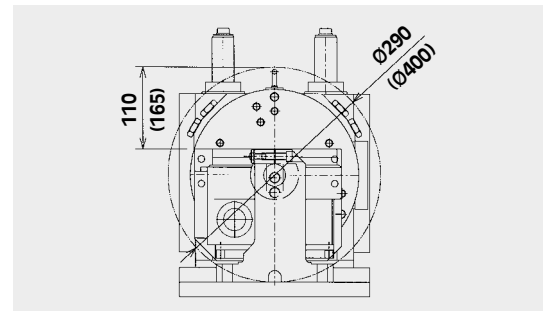

* A counterweight may be required for balance when machining bar-shaped workpieces etc mounted significantly off-center on the

TAIL STOCK TK3

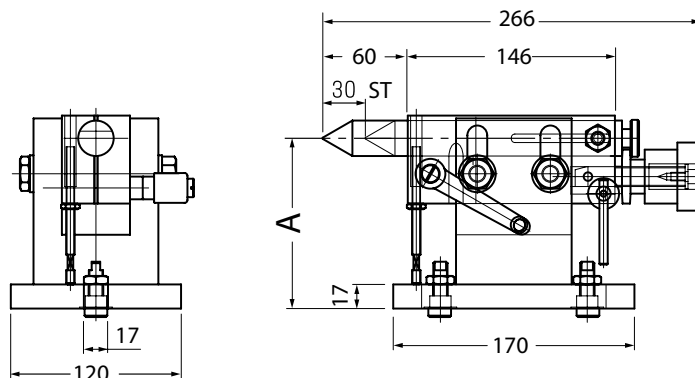
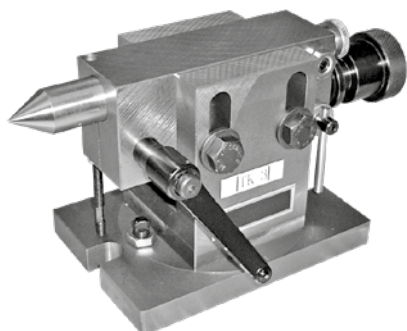

Code	type	A (mm)
51 99 13 21	TK-3	120 - 145
51 99 13 22	TK-3 HI	160 - 185

END SUPPORT

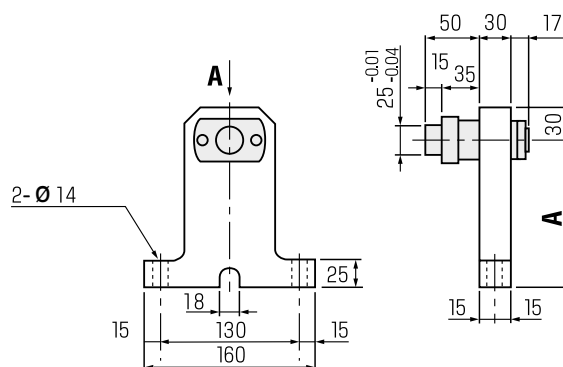
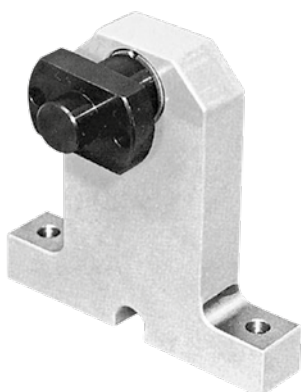

Code	type	A (mm)
51 99 13 23	FES-120	120
51 99 13 24	FES-135	135
51 99 13 25	FES-145	145
51 99 13 26	FES-175	175
51 99 13 27	FES-185	185
51 99 13 28	FES-200	200

MANUAL HANDLE

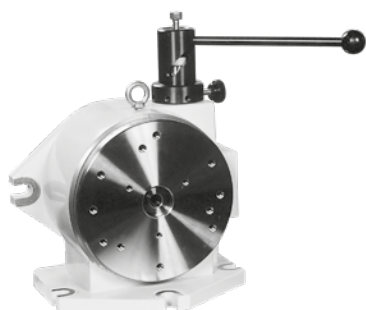

Code	type	stroke
51 99 13 30	MH-1	35
51 99 13 31	MH-2	88
51 99 13 32	MH-3	38
51 99 13 48	MH-5	95

MH-2

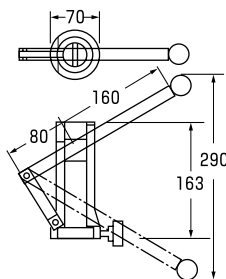

MH-3

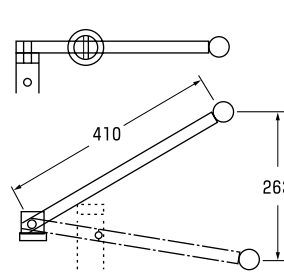

MH-1

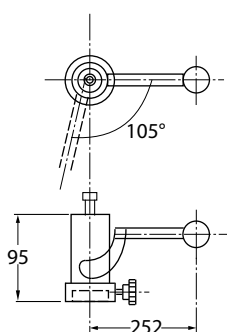

MH-5

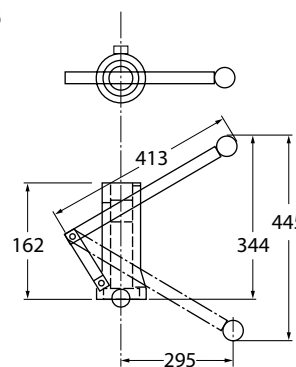

Type	Tailstok	Manual handle	End support
FDM-150	TK-3	MH-3	FES-120
FDR-150-04 (MK)	TK-3	MH-2	FES-120
FD (M)-200 (-360)	TK-3	MH-1	FES-135
FD (M)-200-04	TK-3	MH-2	FES-135
FD (M,R)-230 (-360) (MK)	TK-3	MH-2	FES-145
FDR-230-04 (-360) (MK)	TK-3-HI	MH-2	FES-175
FDM-300	TK-3-HI	MH-2	FES-185
FDMK-340 (-360)	-----	MH-5	FES-200
FDK-450	-----	MH-6	-----

K67



Code		
10 73 12 23	Cartridge 500 g	Grease K67
10 73 12 24	Can 1000 g	Grease K67

GREASING KIT

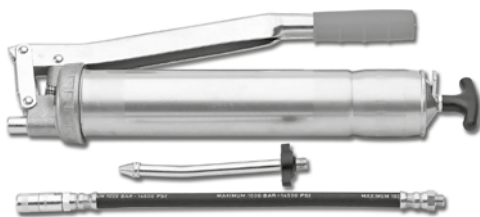

Code
08 37 26

MOUNTING FLANGE FOR MANUAL CHUCK

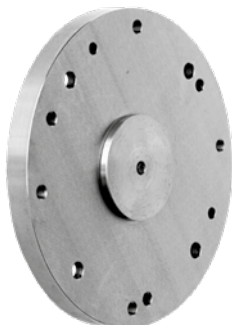

Codice	for type	for chuck	D (mm)
51 99 13 41	FDM-150	SGSF 160-42	170
51 99 13 42	FD-200-04 / FD-200-360 FDM-230 / FDM-230-360 / FDR-230	SGSF 200-55	210
51 99 13 43	FD-300 / FD-300-360 FDMK-340 / FDMK-340-360	SGSF 315-103	310
51 99 13 47	FDK-450	SGSF 400-136	450

PAIR OF KEYS



Code	mm
51 99 13 51	16 x 14
51 99 13 52	16 x 16
51 99 13 53	16 x 18
51 99 13 54	18 x 14
51 99 13 55	18 x 16
51 99 13 56	18 x 18

SGSF MANUAL CHUCK (frontal mounting)

SMW self-centering manual chuck, steel body

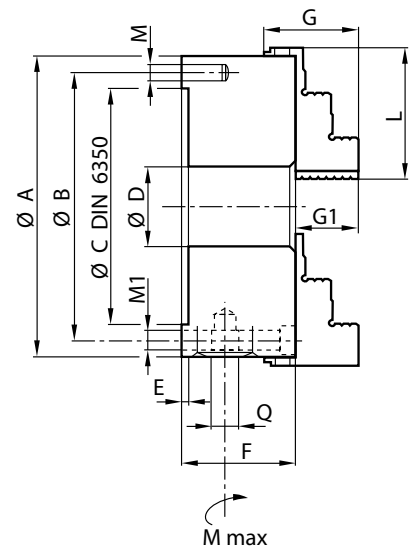
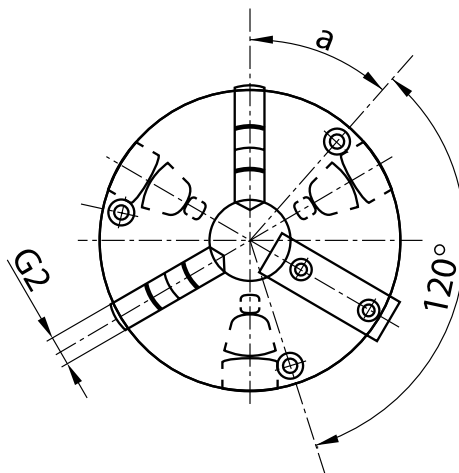

Code		33 03 12 16	33 03 12 20	33 03 12 31	33 03 12 40
Chuck		SGSF 160-42	SGSF 200-55	SGSF 315-103	SGSF 400-136
Attachement DIN 6350	Dim.	FL125	FL160	FL260	FL330
	A mm	160	200	315	400
	B mm	140	176	286	362
H6	C mm	125	160	260	330
	D mm	42	55	103	136
	E mm	4	4	5	5
	F mm	68	78	96,2	108
	G mm	53	54	73	92
	G ₁ mm	32	29	41	55
	G ₂ mm	20	25	32	36
	L mm	70	85	125	145
Front mounting	M ₁ mm	3xM10	3xM10	3xM16	3xM16
	Q mm	11	11	14	17
	a °	102°	42°	42°	45°
Max speed	giri/min.	4500	4000	2800	2000
Torque M max	N•m	120	160	200	280
Weight (w. jaws)	kg	11,2	20	50	90
Moment of inertia	kgm ²	0,03	0,10	0,60	1,80

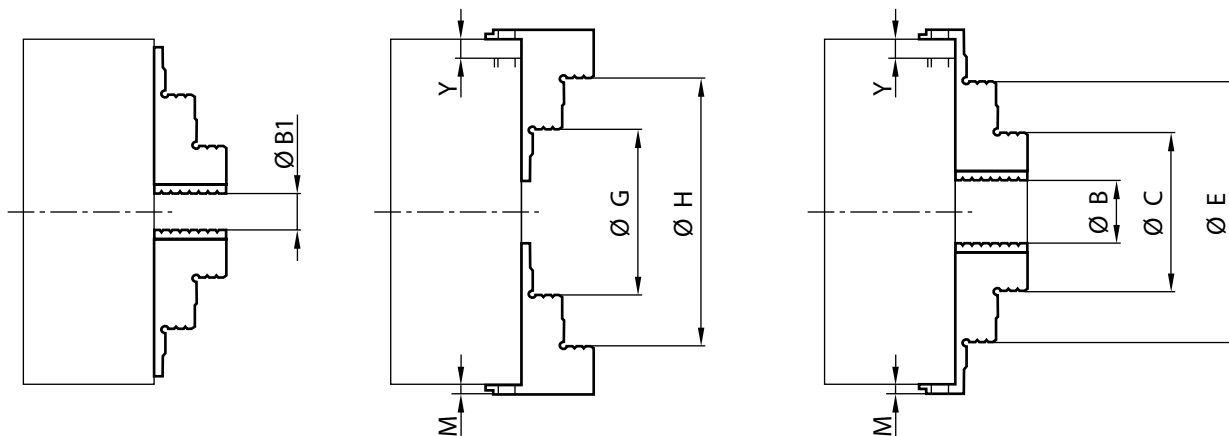

Chuck		SGSF 160-42	SGSF 200-55	SGSF 315-103	SGSF 400-136
Suggested clamping diameters at max. clamping force					
Monoblock jaws	B mm	19-56	22-75	58-115	77-162
	G mm	64-101	78-130	129-199	169-254
	H mm	113-150	146-198	226-296	295-380
	C mm	57-94	68-121	128-184	149-234
	E mm	109-146	136-189	212-281	275-360
	Y mm	0	4	9	16
	M mm	18	22	25	26
Min. clamping diameters with clamping force reduced by 40%					
		3	4	10	10
No. of scroll teeth		2	3	5	5
No. of meshing scroll teets for safety clamping		2	3	5	5

- For max. speed and max. clamping, all teeth shall be meshing.
- For meshing teeth control towards outside dimension (M) toward inside dimension (Y).
- For features exceeding these limits ±16 mm on diameter, shall be reduced by 25%.
- ATTENTION: CLAMPING DIAMETERS HAVE BEEN CALCULATED WITH A.M. MESHING TEETH.

Chuck		SGSF 160-42	SGSF 200-55	SGSF 315-103	SGSF 400-136
Accessories		Codici			
Set-3 GRC		03 65 16 30	03 65 20 30	03 65 31 30	03 65 40 30
Set-3 Soft jaws		03 60 16 30	03 60 20 30	03 60 31 30	03 60 40 30
Set-3 ins. jaws Dx		03 55 16 30	03 55 20 30	03 55 31 30	03 55 40 30
Set-3 ins. jaws Sx		03 56 16 30	03 56 20 30	03 56 31 30	03 56 40 30
Set-3 Rev. jaws		03 63 16 30	03 63 20 30	03 63 31 30	03 63 40 30
Key		02 71 17 00		02 71 31 00	02 71 40 00

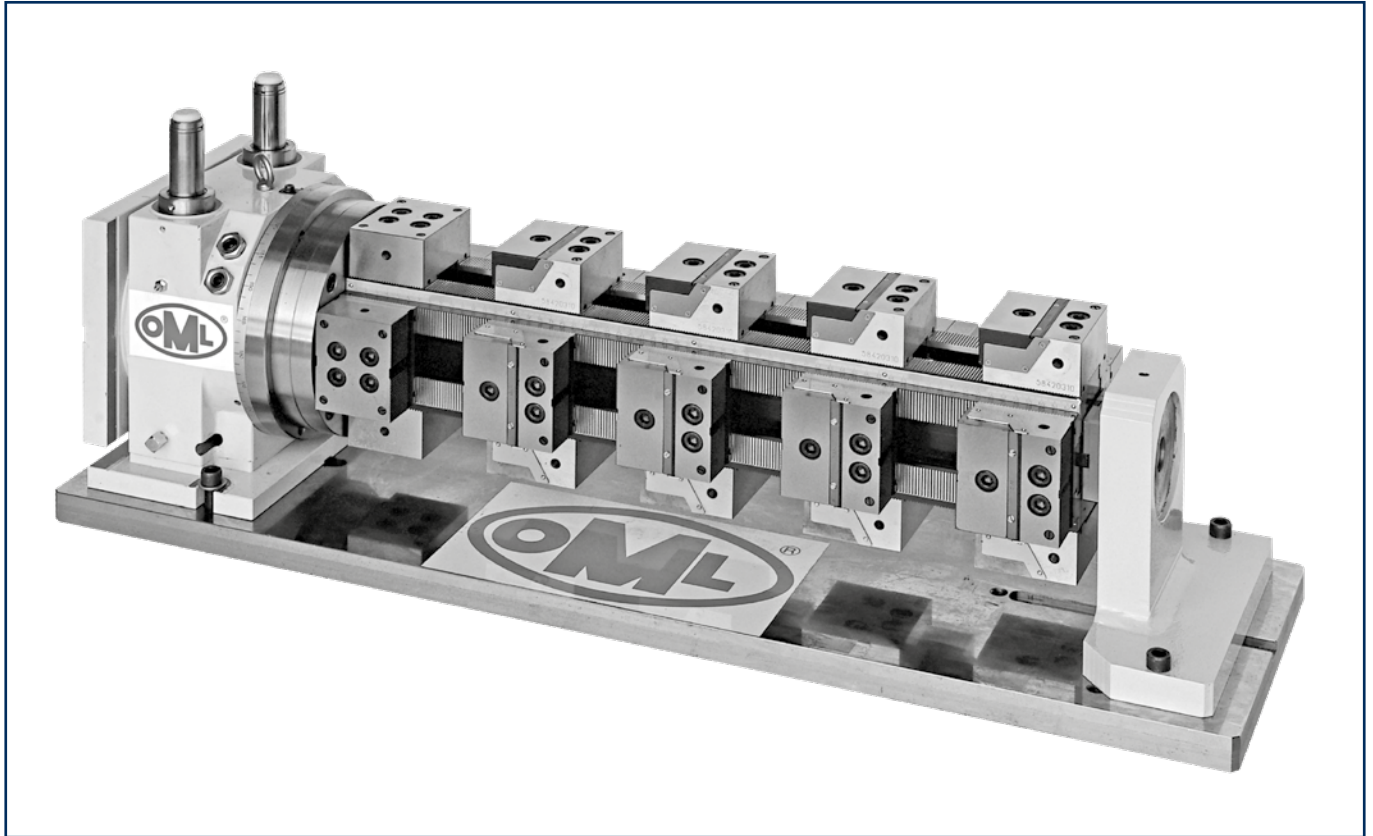

The example shows:

- TOUCHDEX table
- Column CIVI 2000 (General catalogue OML group 6)
- Moveable jaws set CIVI 2000 (General catalogue OML group 6)



The example shows:

- TOUCHDEX table with manual chuck