

Multiple clamping system

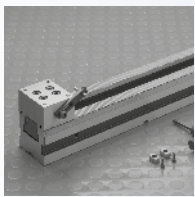

CIVI 2000

Base set

Page 6.2.4

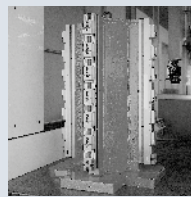

CV-VCS

Page 6.2.13

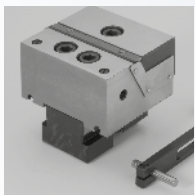

CIVI 2000

Accessories

- Supports

Page 6.2.5



CV-CN

Page 6.2.16



CLAK SYSTEM

Parallels for CIVI 2000

Page 6.2.8

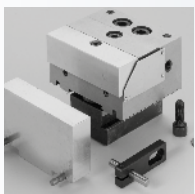

CIVI 2000

Accessories

- Jaws

Page 6.2.9

CIVI 2000

Multiple clamping system

SERRATION COMPARISON CIVI 2000 - TETRABLOK AND COMPETITION (wedge with normal reaction to the axis without friction)

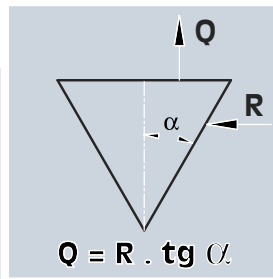

OML

CIVI 2000

pitch 2,5

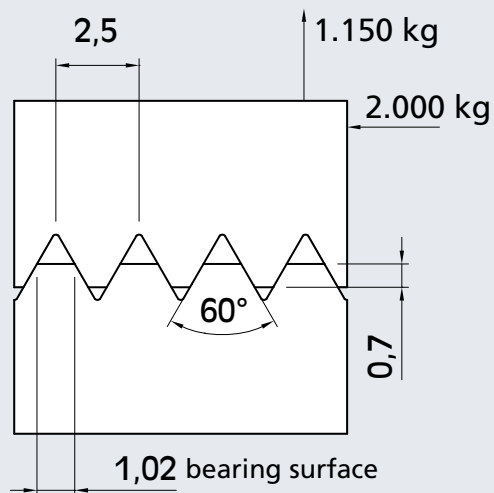

TETRABLOK

pitch 2,0

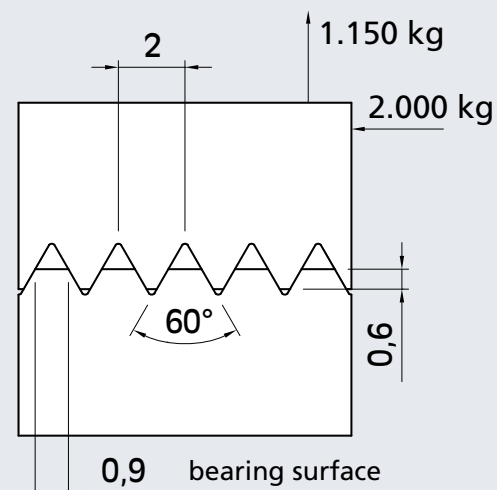

COMPETITION

pitch 1,5

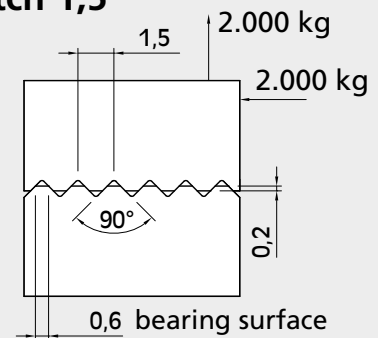

pitch 2,0

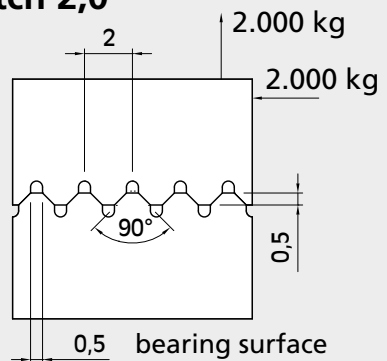

pitch 2,0

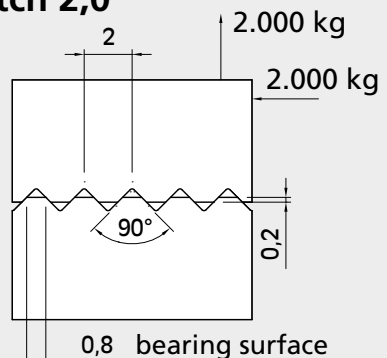

CIVI 2000

Multiple clamping system

Advantages for the user:

- Best use of the machine table
- Wide range of standard accessories
- Highest efficiency due to rapid set-up times
- Maximum flexibility: can be used for single or multi clamping on the machine table and also on tombstones
- Fully protected by covers and guards

OML offers two different multiple clamping systems: CV with serration 2.5 x 60° and TB with serration 2.0 x 60°. Both of these multiple clamping systems come with different jaw widths and lengths.

For the CV system, the "CLAK-SYSTEM" quick change system for jaws and parallels is available as an option. The user can also clamp safe raw parts using jaws fitted with SinterGrip clamping inserts.

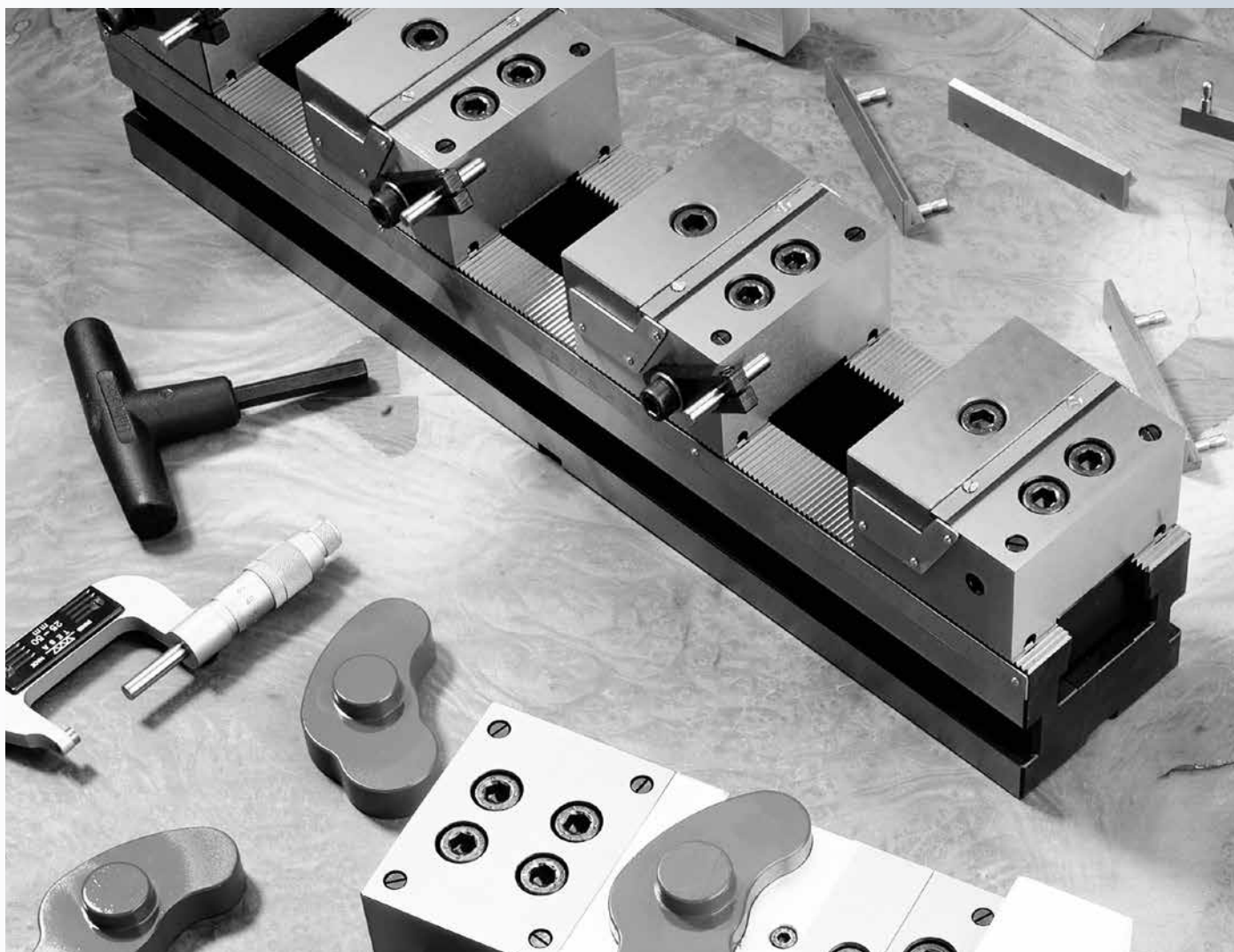



CIVI 2000 is a new interesting modular Multi-Clamping system that reduces downtime and maximizes machine tool productivity

Complete base set with:

1 base (length optional), 1 fixed support smooth/grooved, 1 pair of positioning keys, 1 t-wrench

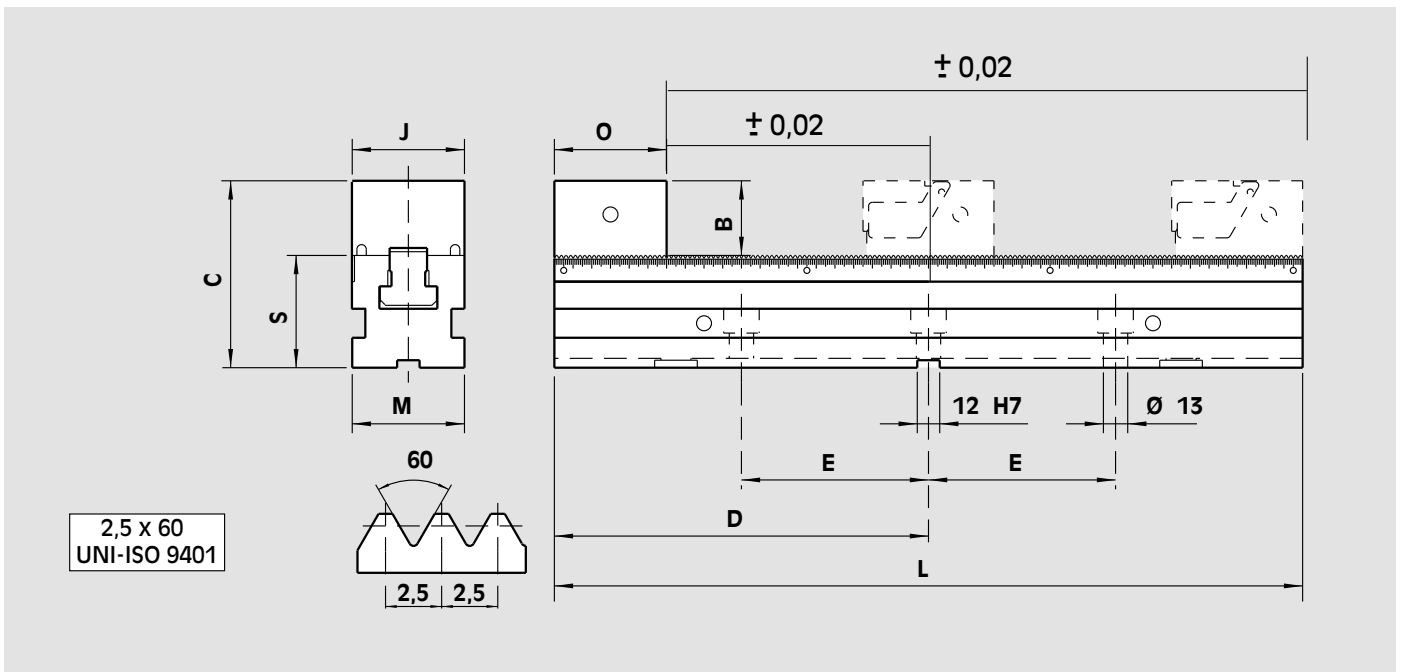

For type	Id. No.	B mm	C mm	D mm	E mm	J mm	L mm	M mm	O mm	S ±0.01 mm	Weight kg	
CV 38-250	77584004			125	100		250				6	
CV 38-400	77584001	40	100	200	100	38	400	60	60	60	9	
CV 38-500	77584002			250	150		500					11
CV 38-630	77584003			315	200		630					13
CV 60-250	77584104	40	100	125	100	60	250	60	60	60	6.5	
CV 60-400	77584101			200	100		400				9.5	
CV 60-500	77584102			250	150		500				11.5	
CV 60-630	77584103			315	200		630				13.5	
CV 90-250	77584204	45	115	125	100	90	250	90	70	70	11	
CV 90-400	77584201			200	100		400				16	
CV 90-500	77584202			250	150		500				19.5	
CV 90-630	77584203			315	200		630				23.5	

Movable jaw set J38 smooth

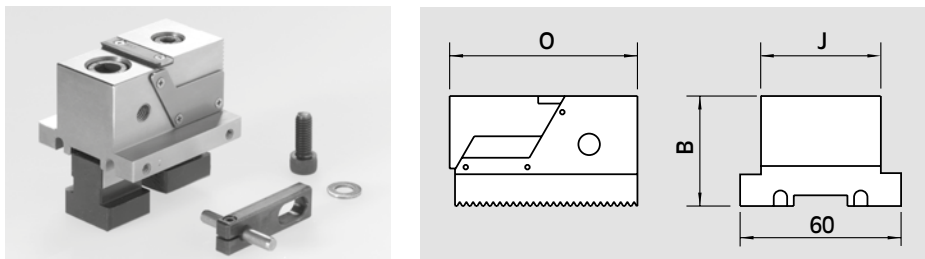

For type	Id. No.	B mm	J mm	O mm	Weight kg
CV 38	77584023	40	38	70	1

Movable jaw set J60-J90 smooth

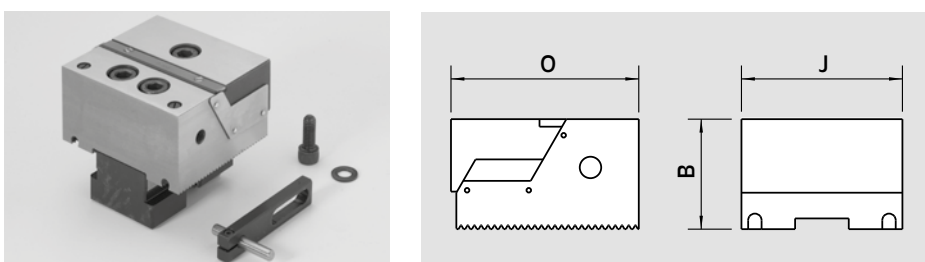

For type	Id. No.	B mm	J mm	O mm	Weight kg
CV 60	77584123	40	60	70	1.4
CV 90	77584223	45	90	80	2.9

Movable jaw set J38 with grooved jaws (for raw workpieces)

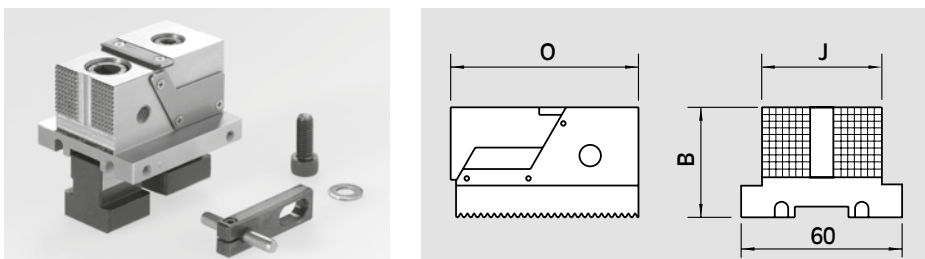

For type	Id. No.	B mm	J mm	O mm	Weight kg
CV 38	77584028	40	38	70	1

Movable jaw set J60-J90 with grooved jaws (for raw workpieces)

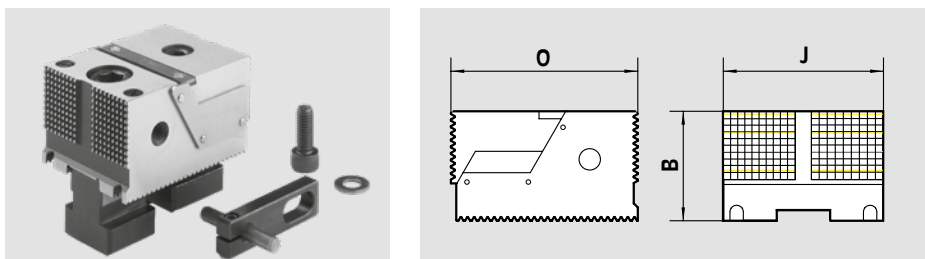

For type	Id. No.	B mm	J mm	O mm	Weight kg
CV 60	77584128	40	60	70	1.4
CV 90	77584228	45	90	80	2.9

Movable set with double jaws

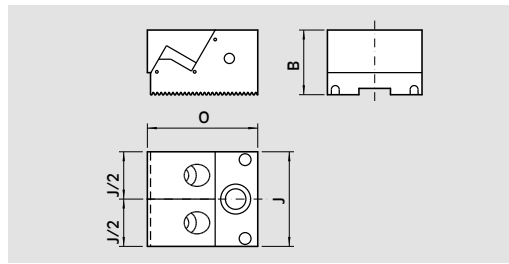
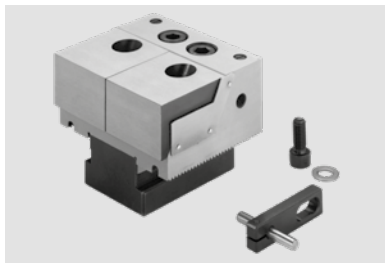

Working example

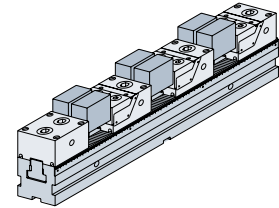

For type	Id. No.	B mm	J mm	O mm	Weight kg
CV 60	77584124	40	60	70	1.5
CV 90	77584224	45	90	80	3

Movable jaw set with aluminium jaws

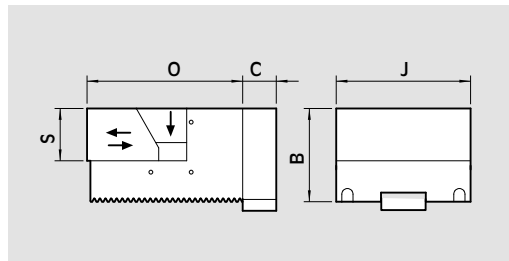

For type	Id. No.	B mm	C mm	J mm	O mm	S mm	Weight kg
CV 60	77584145	40	15	60	69.5	23	1.2
CV 90	77584245	45	20	90	80	25	2.7

Movable jaw set with steel soft jaws

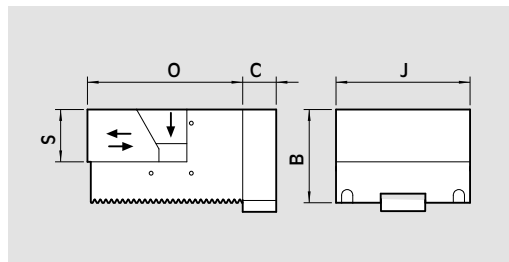

For type	Id. No.	B mm	C mm	J mm	O mm	S mm	Weight kg
CV 60	77584146	40	15	60	69.5	23	1.4
CV 90	77584246	45	20	90	80	25	3

Movable jaw set with steel hardened jaw

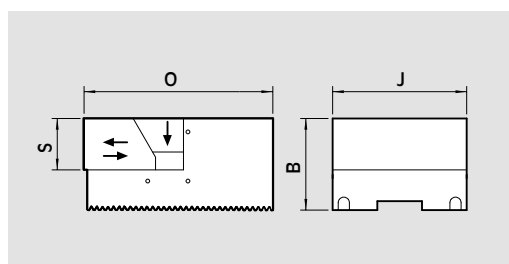
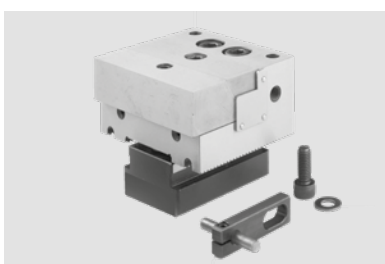

For type	Id. No.	B mm	J mm	O mm	S mm	Weight kg
CV 60	77584147	40	60	69.5	23	1.4
CV 90	77584247	45	90	80	25	3

Fixed support with fixed slide way J38 smooth/grooved jaws

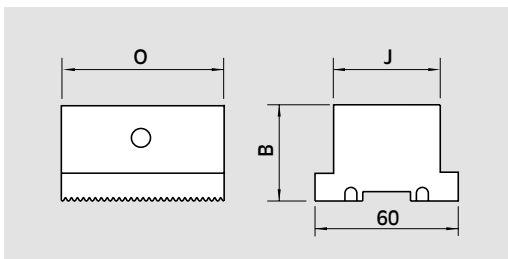
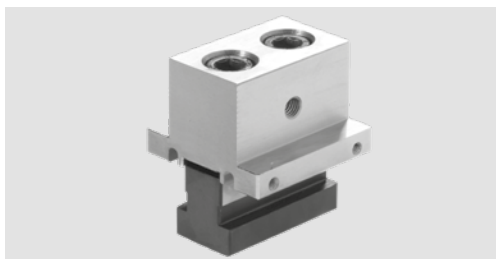

For type	Id. No.	B mm	J mm	O mm	Weight kg
CV 38	58407200	40	38	60	1

Fixed support with fixed slide way J60-J90 smooth/grooved jaws

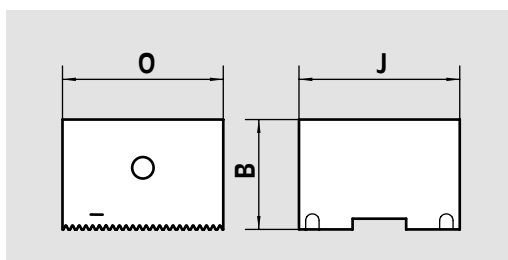

For type	Id. No.	B mm	J mm	O mm	Weight kg
CV 60	58417200	40	60	60	1.4
CV 90	58427200	45	90	70	2.9

Fixed support with fixed slide way J38 with grooved jaws

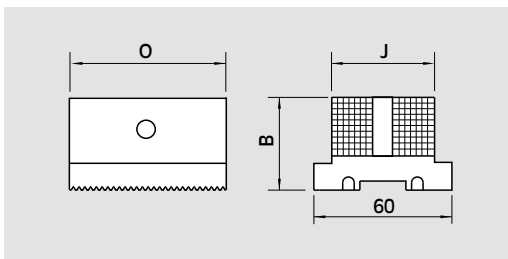
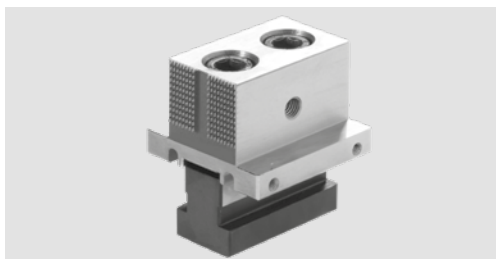

For type	Id. No.	B mm	J mm	O mm	Weight kg
CV 38	58407210	40	38	60	0,87

Fixed support with fixed slide way J60-J90 with grooved jaws

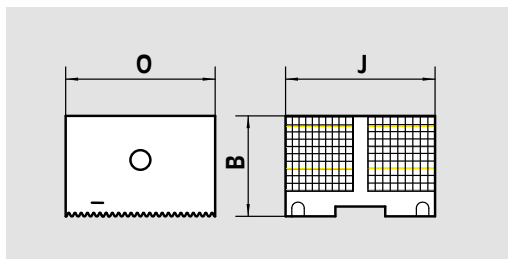
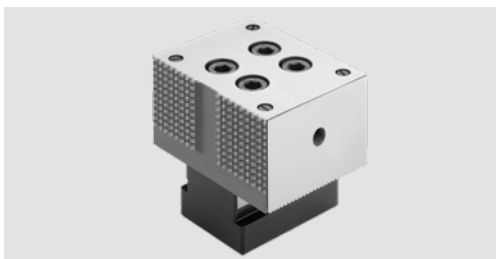

For type	Id. No.	B mm	J mm	O mm	Weight kg
CV 60	58417210	40	60	60	1.4
CV 90	58427210	45	90	70	2.9

PARALLELS FOR CIVI 2000

CLAK-SYSTEM: Quick change for CIVI multiple clamping system

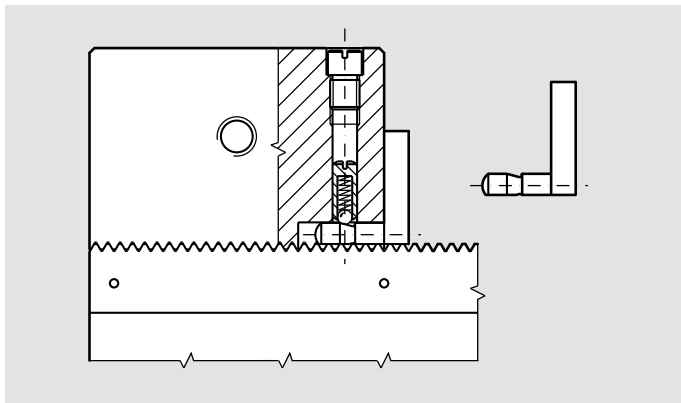

The exclusive and proven CLAK SYSTEM, for the quick replacement of parallels and jaws has been applied for use with the CIVI 2000 equipment with a new patent.

This equipment offers:

- The quick replacement of parallels and jaws
- The elimination of clamps and locks thanks to the patented selflocking system
- The increase in accuracy

All components are heat treated and precision ground.

Set of 4 pair of parallels "Clak System"

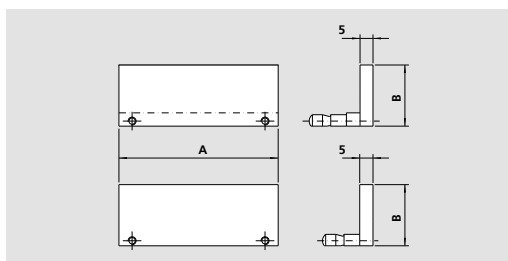

For type	Id. No.	A mm	B mm				Weight kg
			18	23	28	37	
CV 38	58409204	38	18	23	28	37	0.4
CV 60	58419204	60	18	23	28	37	0.49
CV 90	58429204	90	18	23	33	42	0.77

V jaw "Clak System"

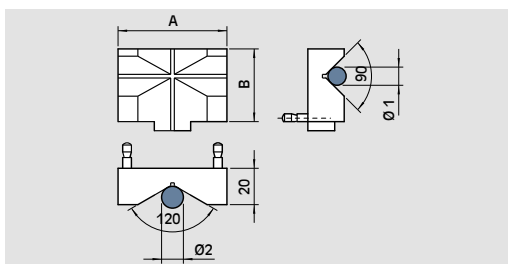

For type	Id. No.	A mm	B mm	Ø 1		Ø 2	
				min. mm	max. mm	min. mm	max. mm
CV 38	58409400	38	40	10	24	9	45
CV 60	58419400	60	40	10	28	11	70
CV 90	58429400	90	45	10	28	11	70

Grooved jaw

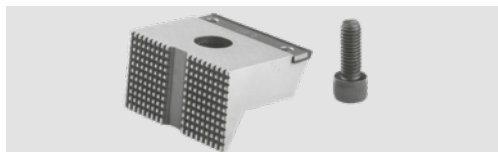

For type	Id. No.
CV 38	58404419
CV 60	58414419
CV 90	58424419

Smooth jaw with guard

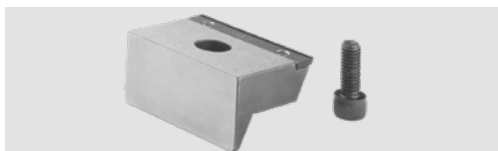

For type	Id. No.
CV 38	58400409
CV 60	58410409
CV 90	58420409

Pair of parallels "Clak System"

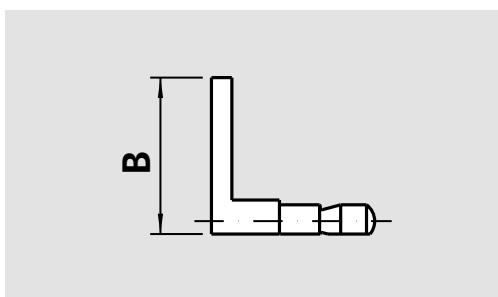
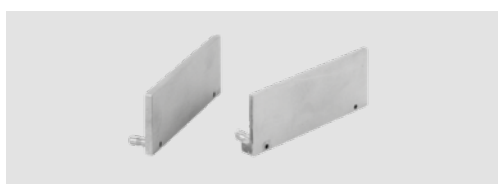

For type	Id. No.	B mm
CV 38	58403518	18
CV 38	58403523	23
CV 38	58403528	28
CV 38	58403537	37
CV 60	58413518	18
CV 60	58413523	23
CV 60	58413528	28
CV 60	58413535	35
CV 60	58413537	37
CV 90	58423518	18
CV 90	58423523	23
CV 90	58423533	33
CV 90	58423540	40
CV 90	58423542	42

Pair of aluminium jaws "Clak System"

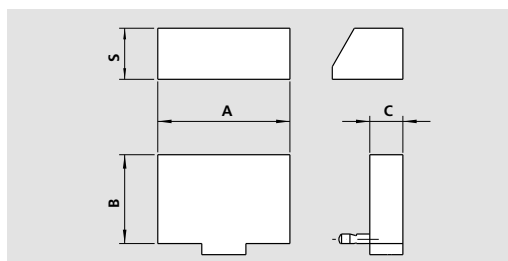
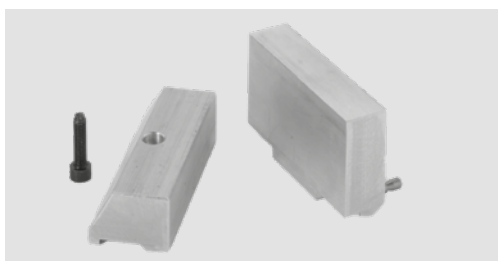

For type	Id. No.	A mm	B mm	C mm	S mm	Weight kg
CV 60	58419549	60	40	15	23	0.19
CV 90	58429549	90	45	20	25	0.4

Pair of soft steel jaws "Clak System"

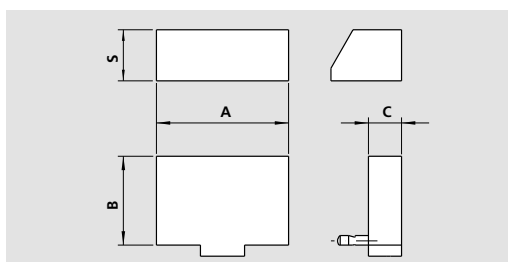
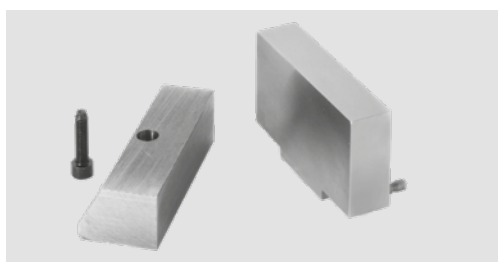

For type	Id. No.	A mm	B mm	C mm	S mm	Weight kg
CV 60	58419649	60	40	15	23	0.58
CV 90	58429649	90	45	20	25	1.2

Hardened jaws



Id. No.	For type	Peso (Kg)
58410459	CIVI 2000/60 x ...	0.300
58420459	CIVI 2000/90 x ...	0.540

Soft steel jaws



Id. No.	For type	Peso (Kg)
58410449	CIVI 2000/60 x ...	0.300
58420449	CIVI 2000/90 x ...	0.540

Aluminium jaws



Id. No.	For type	Peso (Kg)
58410439	CIVI 2000/60 x ...	0.125
58420439	CIVI 2000/90 x ...	0.220

Work stop



Id. No.	For type	
58315010	CIVI 2000/38/60 x ...	for fixed support
58325010	CIVI 2000/90 x ...	for fixed support
58315020	CIVI 2000/38/60/90 x ...	for movable support

Pair of clamps complete with screw and T-nuts

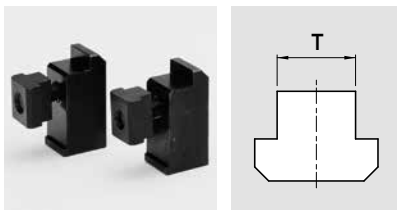

Id. No.						For type
mm 12	mm 14	mm 16	mm 18	mm 20	mm 22	
58012792	58012793	58012794	58012795	58012796	58012797	CIVI 2000/38/60 x ...
58022792	58022793	58022794	58022795	58022796	58022797	CIVI 2000/90 x ...

Pair of standard positioning keys

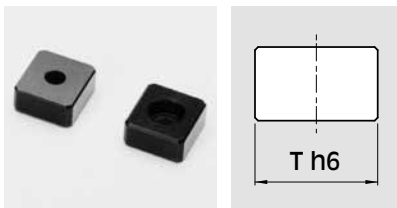

Id. No.	For type	T h6 (mm)
58011592	CIVI 2000/38/60 x ...	12
58011592	CIVI 2000/90 x ...	12

Pair of special positioning keys

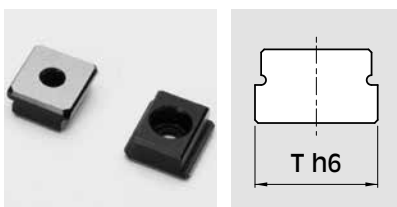

Id. No.						For type
mm 12 - h6	mm 14 - h6	mm 16 - h6	mm 18 - h6	mm 20 - h6	mm 22 - h6	
-	58011593	58011594	58011595	58011596	58011597	CIVI 2000/38/60 x ...
-	58011593	58011594	58011595	58011596	58011597	CIVI 2000/90 x ...

Clamping capacity

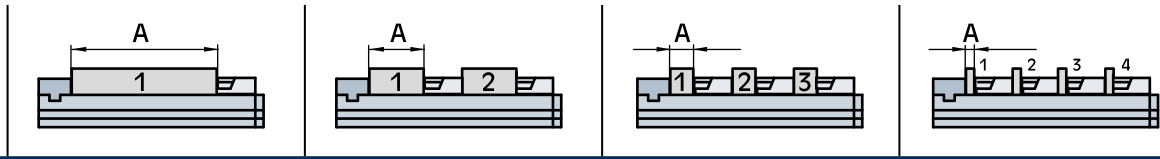

	A max. mm			
CIVI 2000 38/60-250	120	25	-	-
CIVI 2000 38/60-400	270	100	43	15
CIVI 2000 38/60-500	370	150	76	40
CIVI 2000 38/60-630	500	215	120	73
CIVI 2000 90-250	99	-	-	-
CIVI 2000 90-400	249	84	29	-
CIVI 2000 90-500	349	134	62	26
CIVI 2000 90-630	479	199	106	59

Multiple clamping system for 4 workpieces (example)

Set base complete and 4 sets of movable jaws

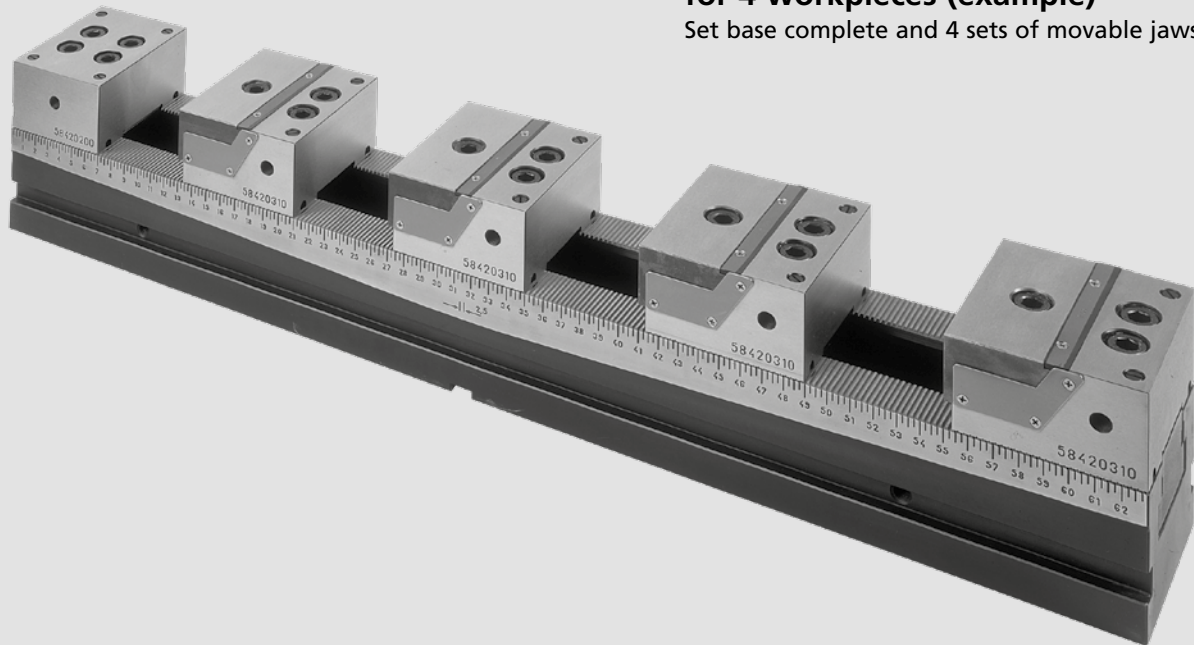

Example of assembling with soft jaws

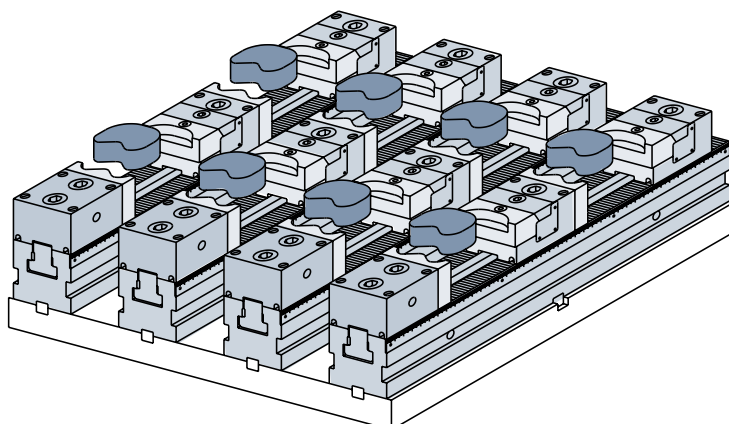

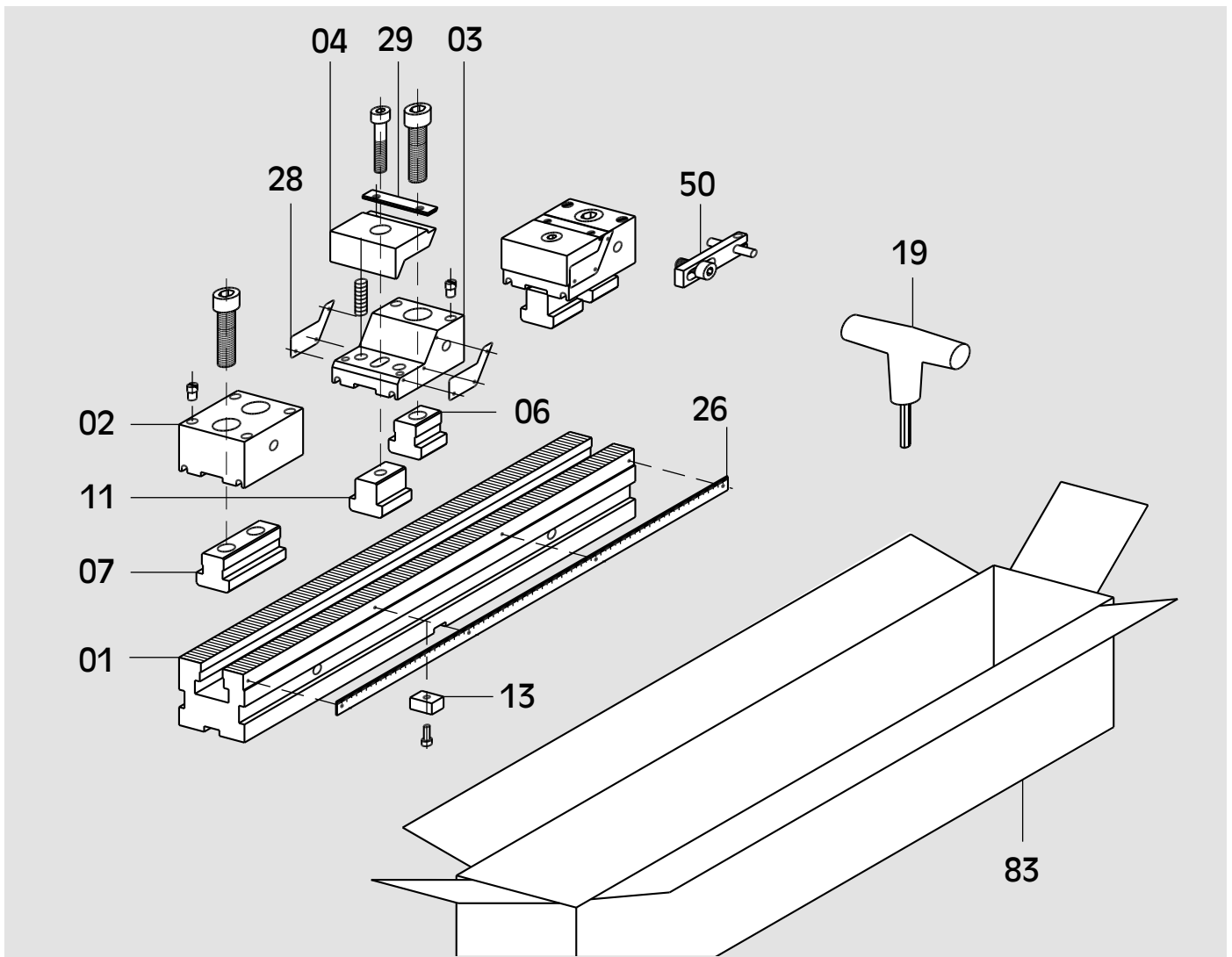

Description

01	Base	07	Nuts	28	Casing for protection
02	Fixed support	11	Nuts	29	Guard
03	Movable support	13	Positioning keys	50	Work stop
04	Jaw	19	T-wrench	83	Cardboard box
06	Nuts	26	Steel rule		

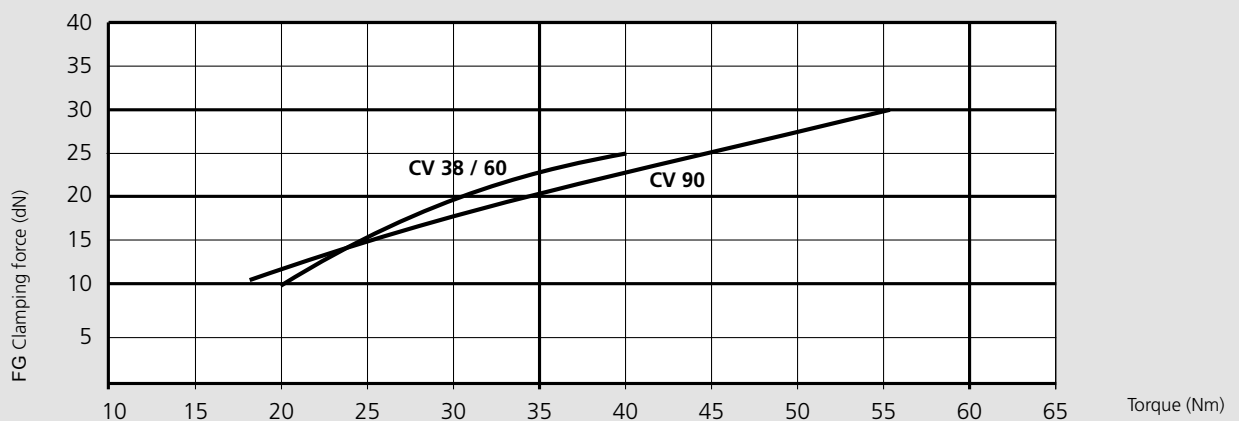



One possible configuration

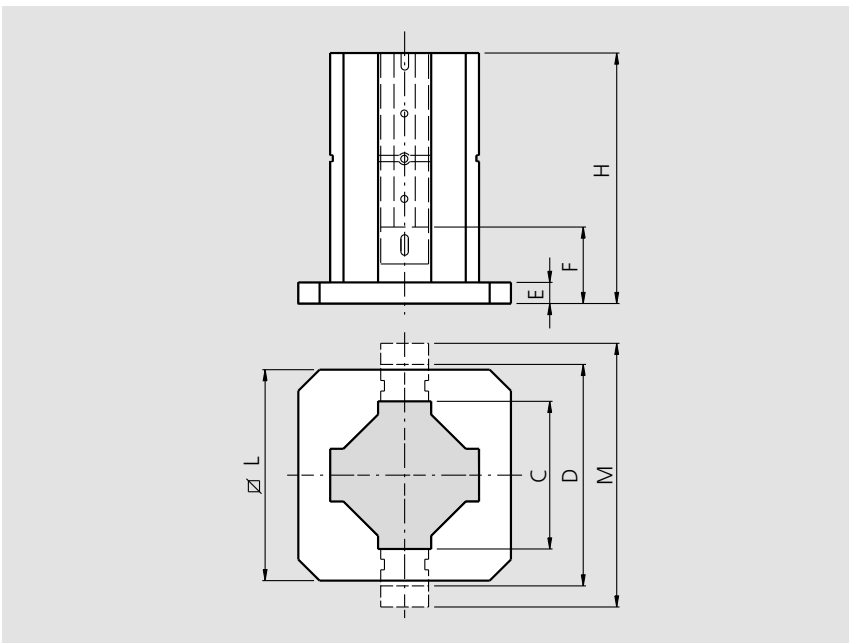
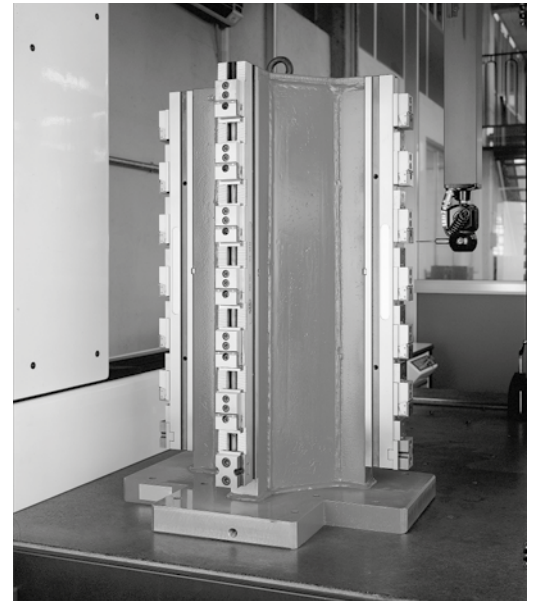

	For type	Id. No.	C mm	D mm	E mm	F mm	H mm	L mm	M mm	Weight kg
Steel	CV-VCS 38/60-400	58428011	250	370	40	120	460	400	450	110
	CV-VCS 38/60-500	58428021	250	370			560	400	450	123
	CV-VCS 38/60-500	58428022	300	420			560	500	500	165
	CV-VCS 38/60-630	58428031	250	370			690	400	450	142
	CV-VCS 38/60-630	58428032	300	420			690	500	500	187
	CV-VCS 38/60-630	58428033	380	500			690	630	580	261
	CV-VCS 90-400	58428011	250	390	40	130	460	400	480	110
	CV-VCS 90-500	58428021	250	390			560	400	480	123
	CV-VCS 90-500	58428022	300	440			560	500	530	165
	CV-VCS 90-630	58428031	250	390			690	400	480	142
	CV-VCS 90-630	58428032	300	440			690	500	530	187
	CV-VCS 90-630	58428033	380	520			690	630	610	261
Aluminium	CV-VCS 38/60-630	58427931	250	370	40	120	690	400	450	66
	CV-VCS 38/60-630	58427932	250	370			690	500	450	76
	CV-VCS 38/60-630	58427933	250	500			690	630	580	122
	CV-VCS 90-630	58427931	250	390	40	130	690	400	480	66
	CV-VCS 90-630	58427932	250	390			690	500	480	76
	CV-VCS 90-630	58427933	250	520			690	630	610	122

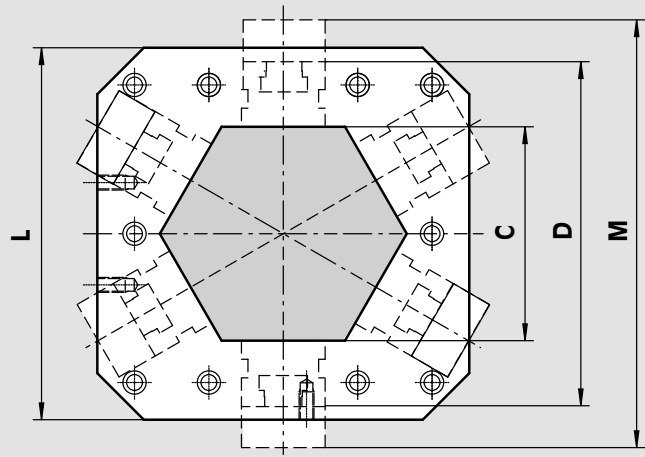
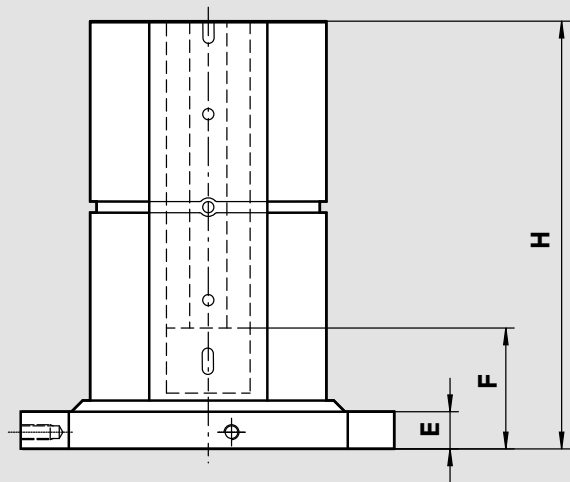
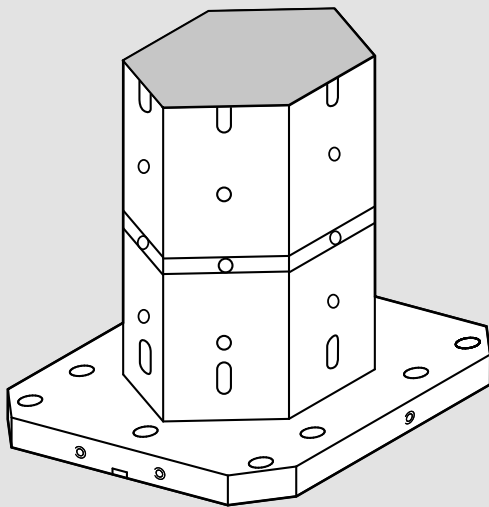

	For type	Id. No.	C mm	D mm	E mm	F mm	H mm	L mm	M mm	Weight kg	
Steel	CIVI 2000/38/60-400	58428511	250	370	40	120	460	400	450	119	
	CIVI 2000/38/60-500	58428521	250	370			560	400	450	138	
	CIVI 2000/38/60-500	58428522	250	370			560	500	450	165	
	CIVI 2000/38/60-630	58428531	250	370			690	400	450	160	
	CIVI 2000/38/60-630	58428532	250	370			690	500	450	188	
	CIVI 2000/38/60-630	58428533	380	500			690	630	580	308	
	Steel	CIVI 2000/90-400	58428511	250	390	40	130	460	400	480	119
		CIVI 2000/90-500	58428521	250	390			560	400	480	138
		CIVI 2000/90-500	58428522	250	390			560	500	480	165
		CIVI 2000/90-630	58428531	250	390			690	400	480	160
		CIVI 2000/90-630	58428532	250	390			690	500	480	188
		CIVI 2000/90-630	58428533	380	520			690	630	610	308
Aluminium	CIVI 2000/38/60-630	58427531	250	370	40	120	690	400	450	68	
	CIVI 2000/38/60-630	58427532	250	370			690	500	450	79	
	CIVI 2000/38/60-630	58427533	380	500			690	630	580	126	
	Aluminium	CIVI 2000/90-630	58427531	250	390	40	130	690	400	480	68
		CIVI 2000/90-630	58427532	250	390			690	500	480	79
		CIVI 2000/90-630	58427533	380	520			690	630	610	126

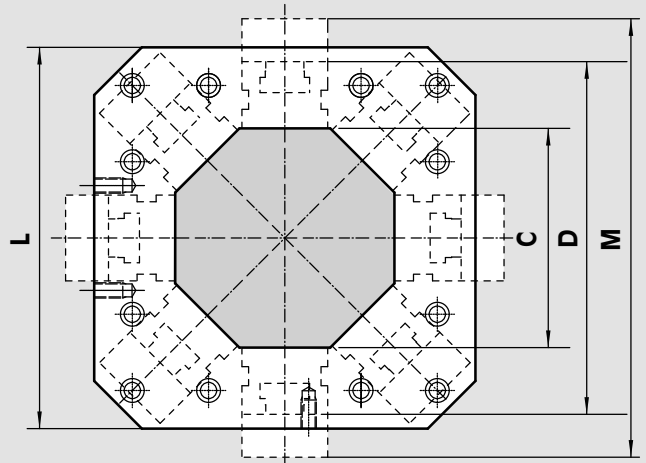
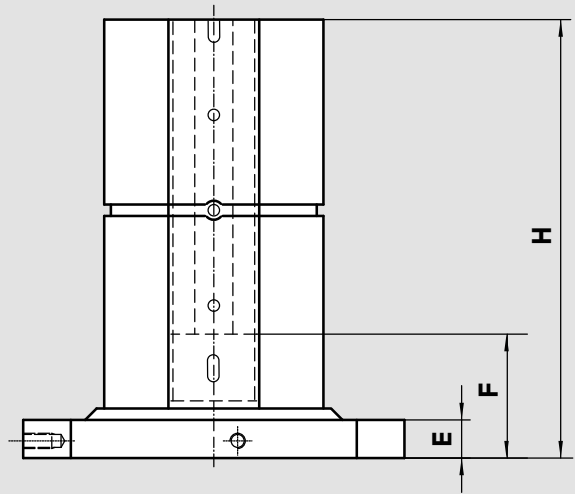
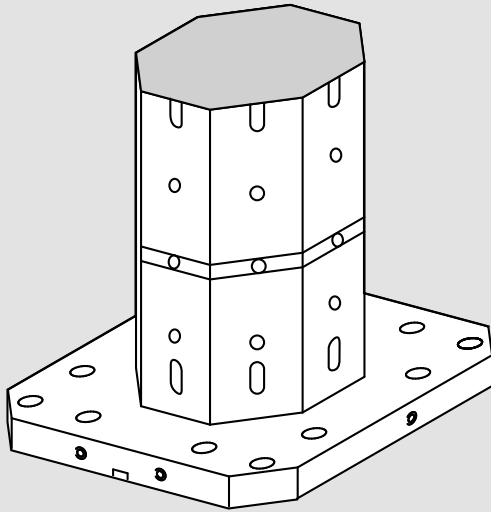

	For type	Id. No.	C mm	D mm	E mm	F mm	H mm	L mm	M mm	Weight kg	
Steel	CIVI 2000/38/60-400	58428611	250	370	40	120	460	400	450	116	
	CIVI 2000/38/60-500	58428621	250	370			560	400	450	133	
	CIVI 2000/38/60-500	58428622	250	370			560	500	450	162	
	CIVI 2000/38/60-630	58428631	250	370			690	400	450	155	
	CIVI 2000/38/60-630	58428632	250	370			690	500	450	183	
	CIVI 2000/38/60-630	58428633	380	500			690	630	580	300	
	Aluminium	CIVI 2000/90-400	58428611	250	390	40	130	460	400	480	116
		CIVI 2000/90-500	58428621	250	390			560	400	480	133
		CIVI 2000/90-500	58428622	250	390			560	500	480	162
		CIVI 2000/90-630	58428631	250	390			690	400	480	155
		CIVI 2000/90-630	58428632	250	390			690	500	480	183
		CIVI 2000/90-630	58428633	380	500			690	630	610	300



Working example

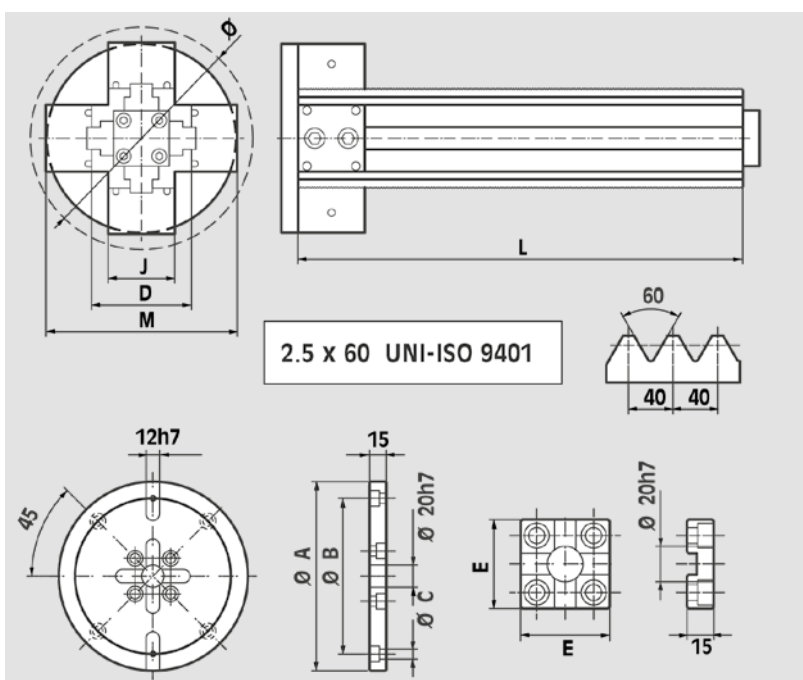
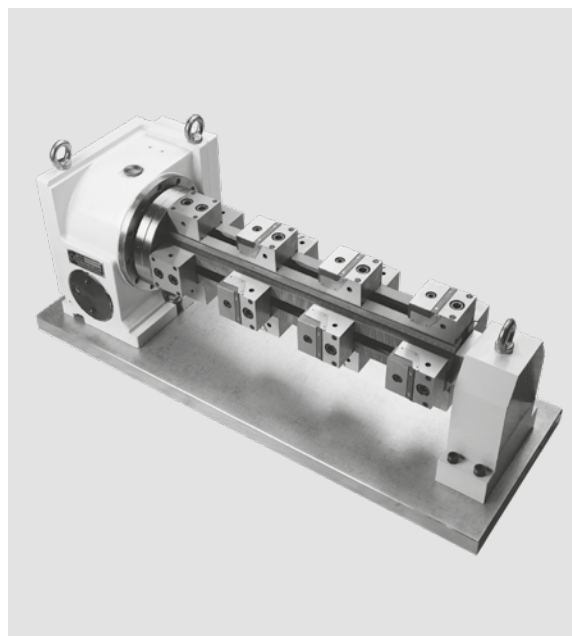

For Type	Id. No.	J mm	D mm	M mm	L mm	Ø rot. mm	Ø A mm	Ø B mm	Ø C mm	E mm	Weight kg
CV-CN 60-400	77584111				400						19
CV-CN 60-500	77584112	60	90	170	500	200	170	140	9	50	23
CV-CN 60-630	77584113				630						29
CV-CN 90-400	77584211				400						34
CV-CN 90-500	77584212	90	115	205	500	230	210	180	11	70	41
CV-CN 90-630	77584213				630						50